

CAMs

- **CAM Mechanisms**
- **Classification of CAM Mechanisms**
- **CAM Nomenclature**
- **Design Considerations**
- **Basic Curves**
 - **SVAJ Diagrams**
 - **Simple Harmonics**
 - **Cycloids**

Transforming a Four Bar Linkage to a Cam

Fixed Polode

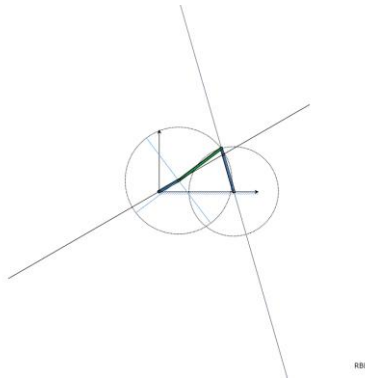

Inversion: Moving Polode

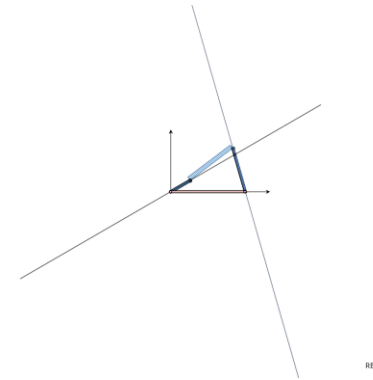

Polodes Combined

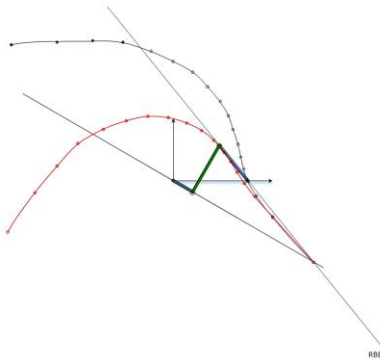

Cam

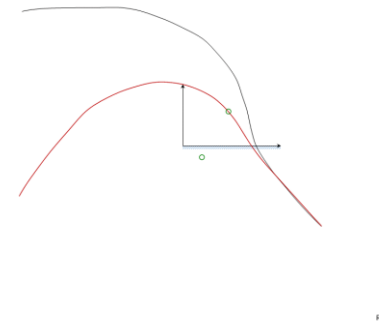

CAM Mechanisms

- A **CAM** is a Mechanical component of a machine
- Used to transmit motion to the **FOLLOWER** component through a prescribed motion
- The **FRAME** supports the bearing surfaces for the CAM and FOLLOWER

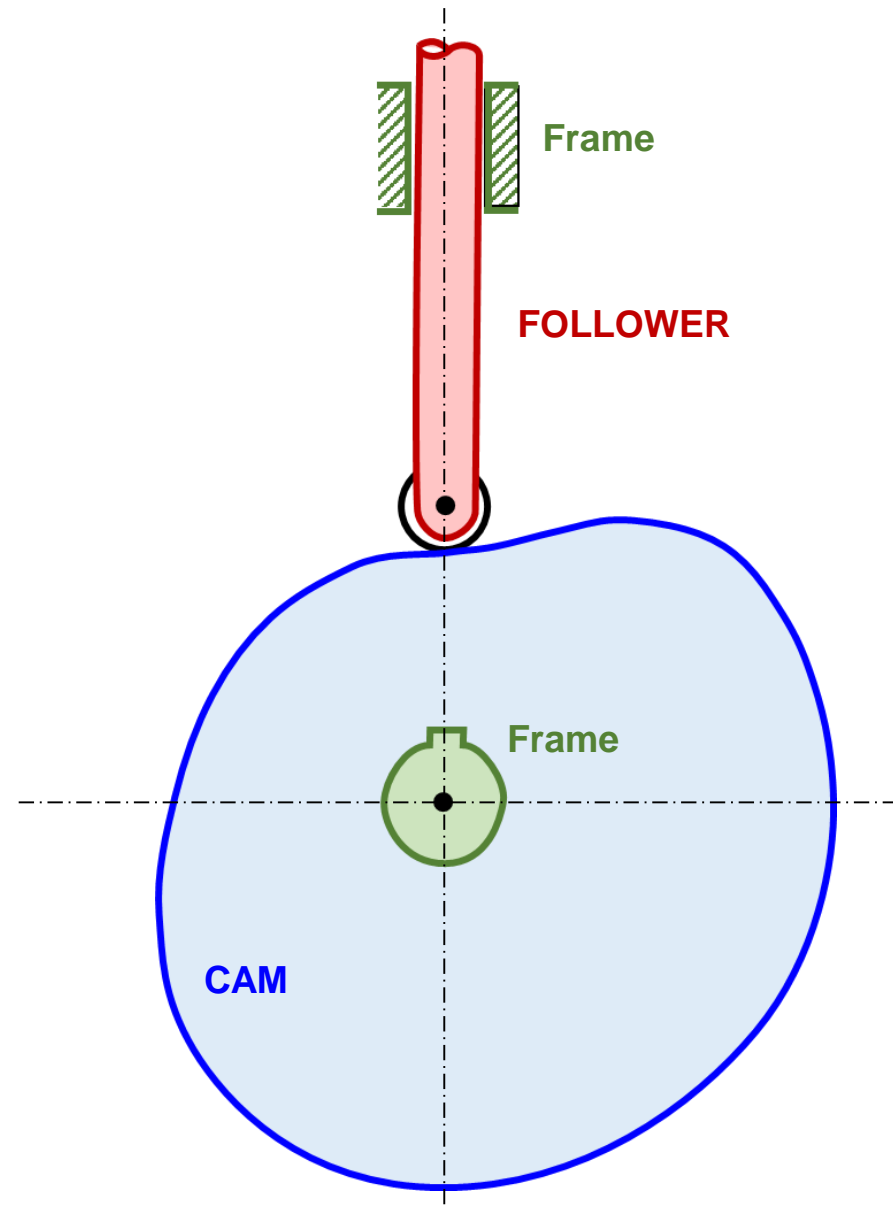

Complex Design Requirements

- **Objective: satisfy a number of motion and work function requirements**
 - **Wheel mechanisms (e.g., gears and friction drives) and flexible drives (e.g., belts and chains)**
 - cannot accommodate complex requirements
 - **Designer must choose between**
 - CAM mechanisms
 - Linkage mechanisms

CAMs v. LINKAGES

CAMs	Linkages
Easily designed to coordinate large number of input-output motion requirements	Satisfy limited number of input-output motion requirements
Can be made small and compact	Occupy more space
Easy to obtain dynamic balance	Difficult and complicated analysis involved in dynamic balance

CAMs v. LINKAGES

CAMs	Linkages
Expensive to produce	Less expensive to produce
Subject to surface wear	Joint wear is non-critical and quieter in operation

Example: Internal Combustion Engine Valves

- **Must convert rotation to translation**
- **Valves must remain closed during the compression and firing strokes of the engine**
- **The velocities of the valves must be zero (dwell) during the intake and exhaust strokes of the engine**

Potential Mechanisms

- Must produce a translation
 - Rise-Dwell-Return-Dwell

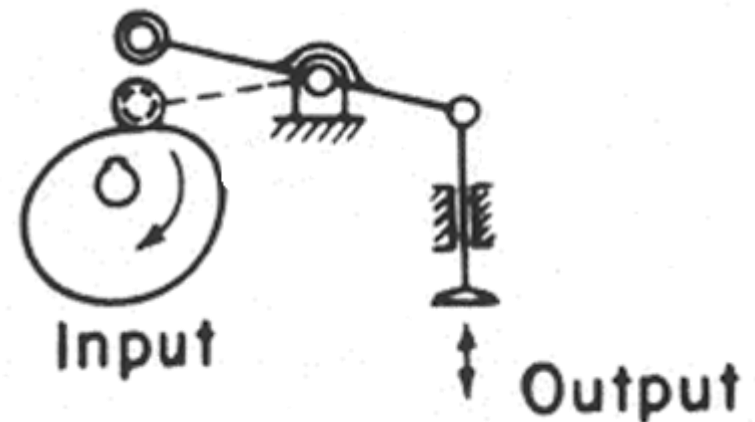
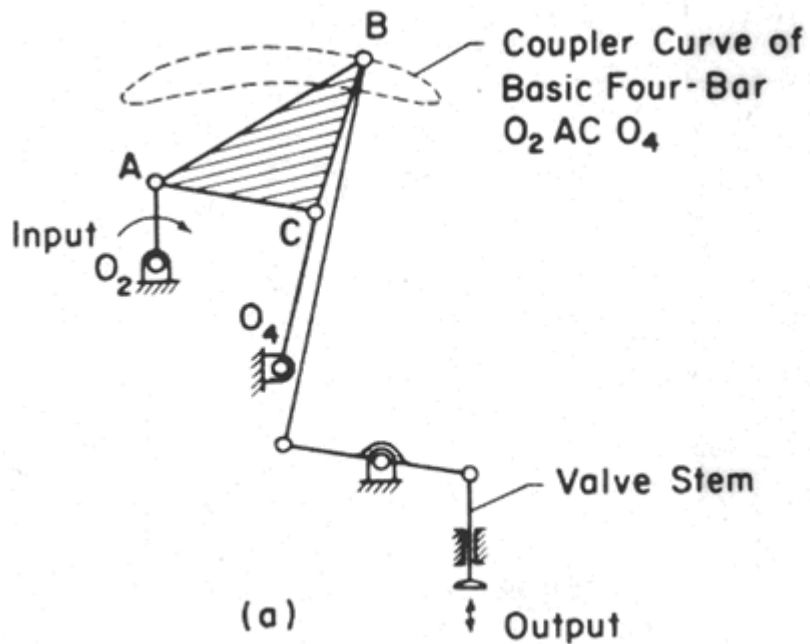

Standard Engine Designs

Overhead Valve Engine

- Tappet, push rod, rocker arm

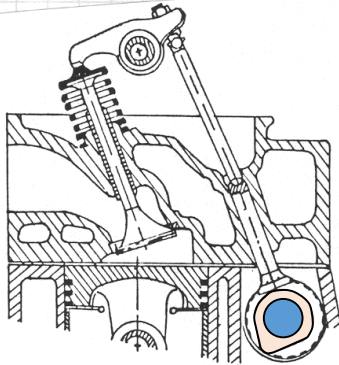

Overhead Cam Shaft

- Activated by valve levers

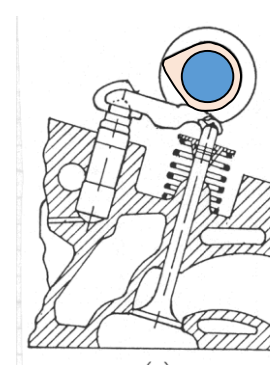

CAM Shaft

- Activated by Rocker

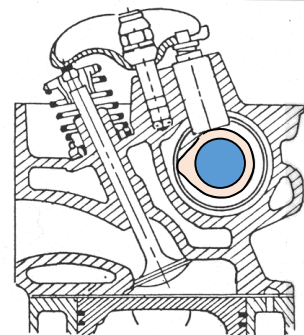

Twin Overhead Cam Shaft

- Direct Activation

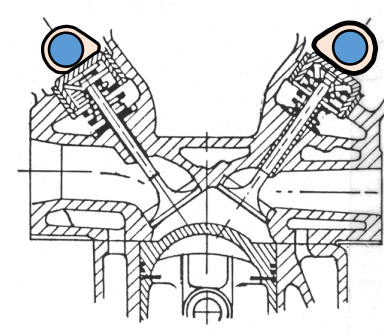

CAM Mechanisms

Modes of Input/Output Motion

- Rotating CAM
Translating Follower
- Rotating CAM
Rotating Follower
 - follower arm swings or oscillates in a circular arc with respect to the follower pivot

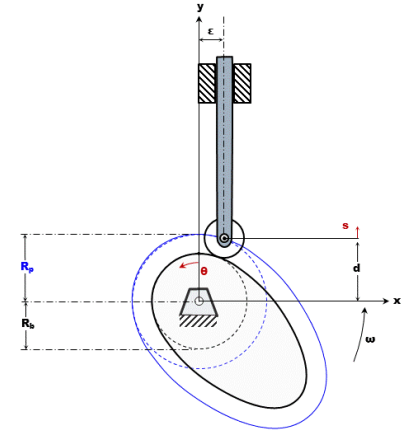

RBB

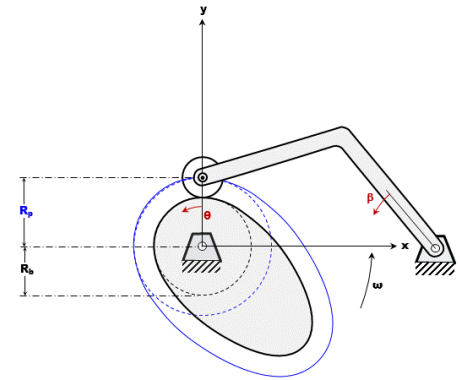

RBB

CAM Mechanisms

Modes of Input/Output Motion

- Translating CAM
Translating Follower

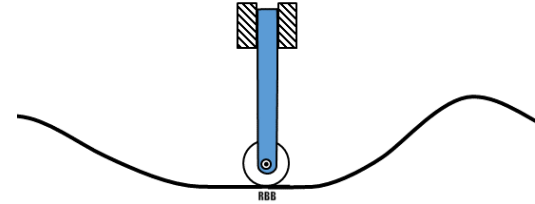

- Stationary CAM
Translating Follower

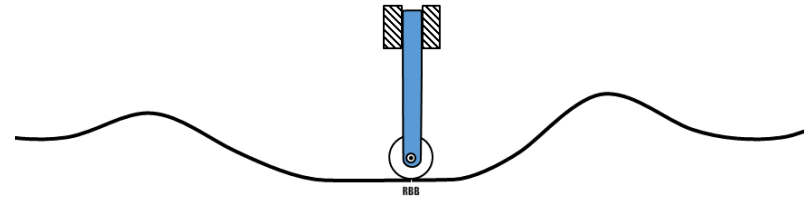

- Translating CAM
Rotating Follower

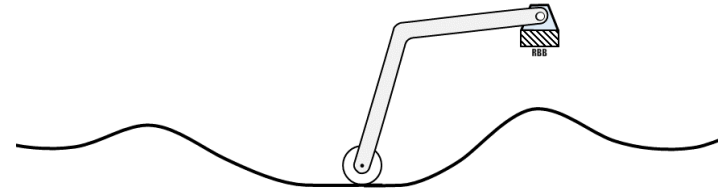

- Stationary CAM
Rotating Follower

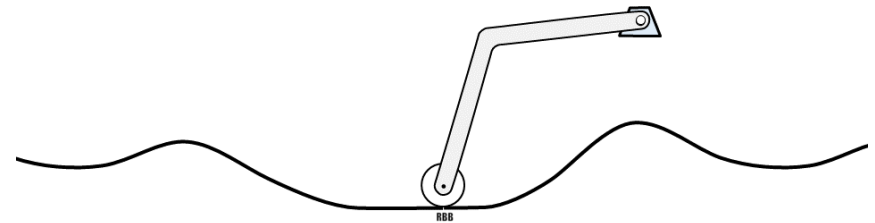

Follower Configurations

- Knife-Edge

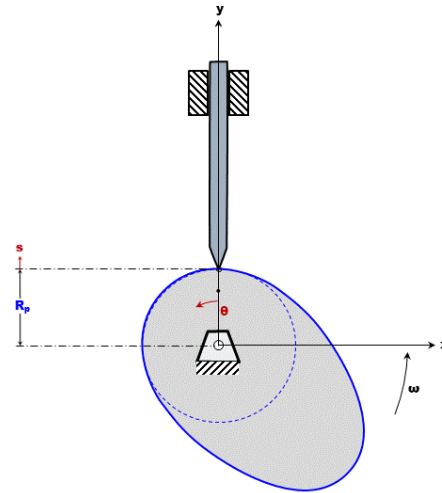

RBB

- Roller

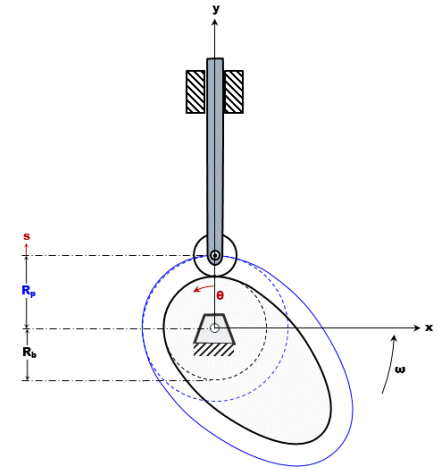

RBB

- Flat-Face

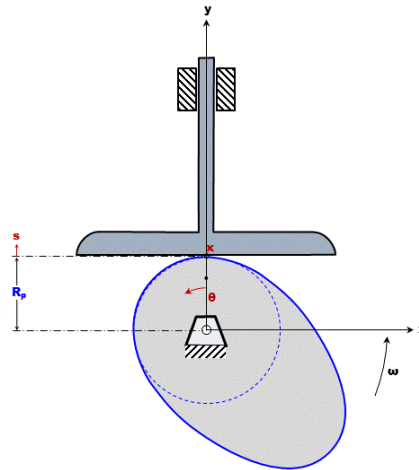

RBB

- Mushroom

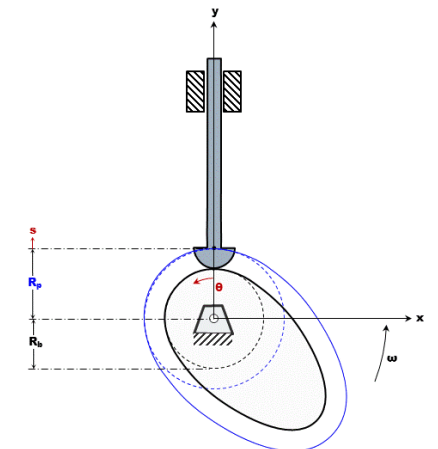

RBB

CAM Mechanisms

Follower Arrangements

- In-Line
 - Centerline of follower passes through the centerline of the cam shaft
- Offset Follower
 - centerline of the follower does not pass through the centerline of the cam shaft
 - offset causes a reduction of the side thrust present in the roller follower

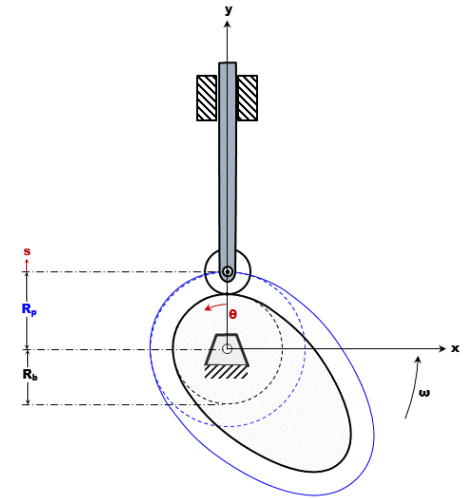

RBB

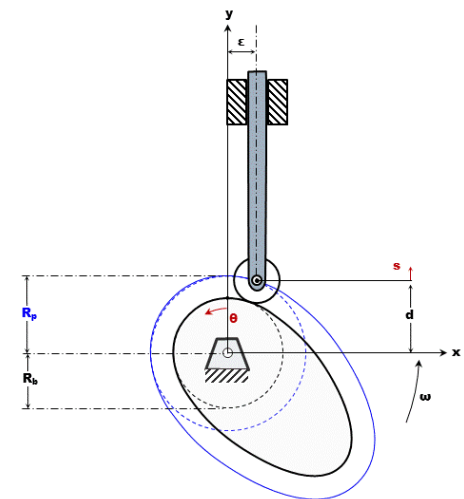

RBB

CAM Mechanisms

CAM Shapes

- **Plate or Disk CAM**
 - Follower moves in a plane perpendicular to the axis of rotation of the cam shaft
 - translating or a swing arm follower must be constrained to maintain contact with CAM profile
- **Grooved CAM or closed CAM**
 - plate CAM with the follower riding in a groove in the face of the cam

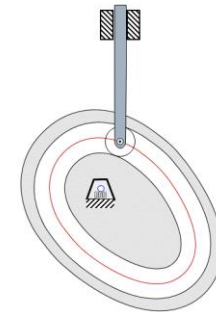
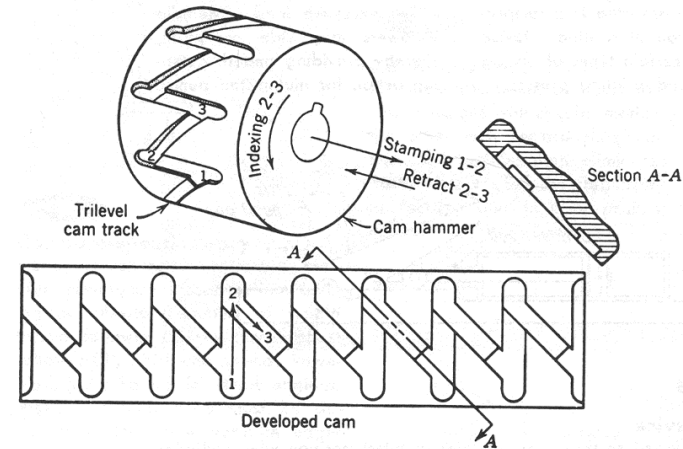

CAM Mechanisms

CAM Shapes

- **Cylindrical CAM or barrel CAM**
 - roller follower operates in a groove cut on the periphery of a cylinder
 - follower may translate or oscillate
 - if the cylindrical surface is replaced by a conical one, a conical CAM results

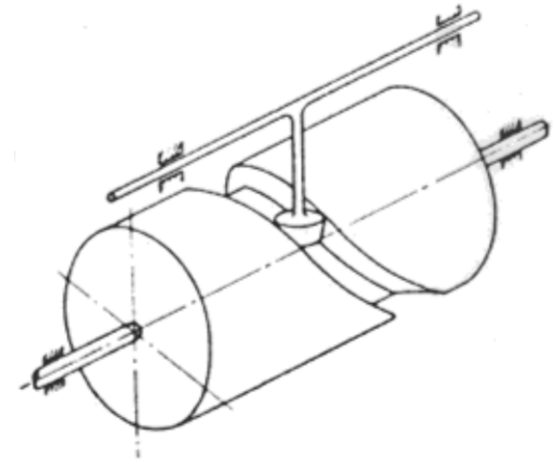

CAM Mechanisms

CAM Shapes

- **Globoidal CAM**

- CAM either convex or concave
- rotating about its axis, the cam has a circumferential contour cut into a surface of revolution
- may be utilized for indexing an intermittent rotating follower

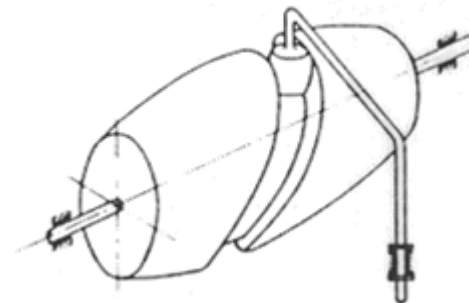
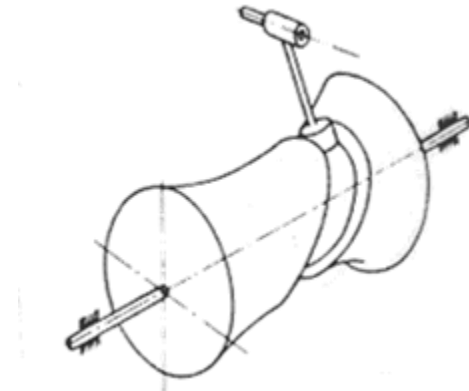

CAM Mechanisms

CAM Shapes

- **End CAM**

- has a rotating portion of a cylinder, a cone, or a sphere, which oscillates a follower having its axis perpendicular to the CAM axis
- follower translates or oscillates, where as the CAM usually rotates
- rarely used because of the cost and the difficulty in cutting it's contour

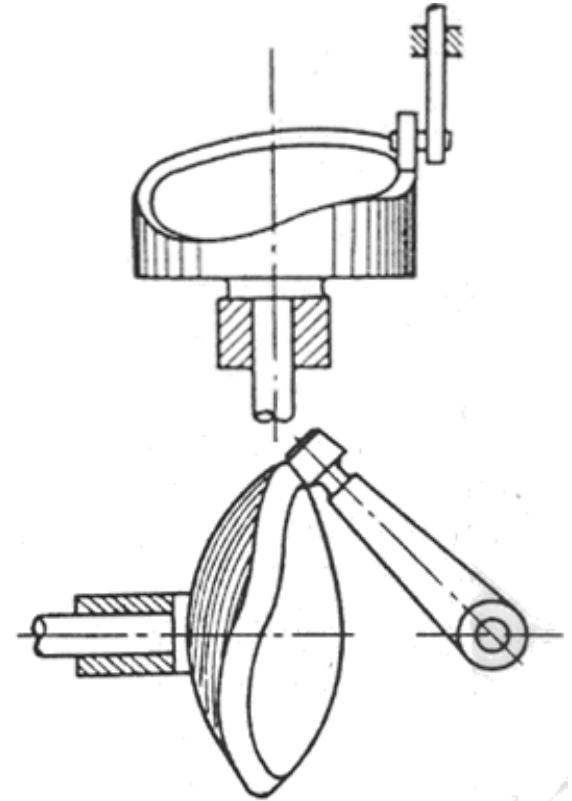

CAM Mechanisms

CAM Shapes

- **Camoid CAM**

- **Three dimensional CAM having a curved face**
 - rotated about the longitudinal axis
 - moved relative to the follower along longitudinal axis
- **Position of translating follower is dependent upon**
 - CAM angular position
 - translational position

For All CAMs The Follower Must Be Constrained

- Gravity constraint

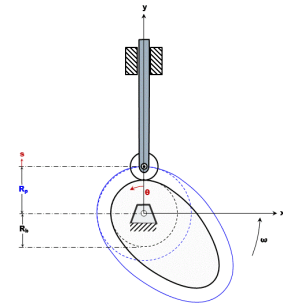
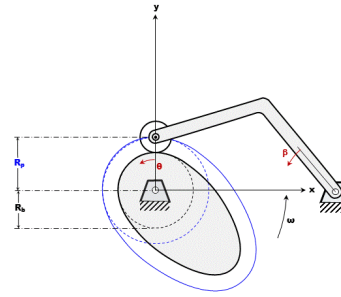

- Spring constraint

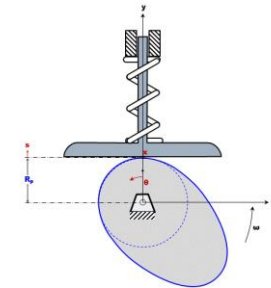
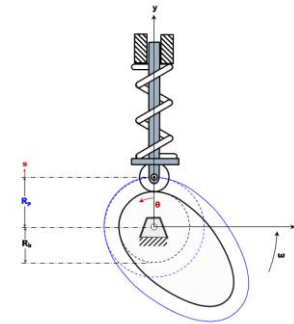

- Positive mechanical constraint

- Conjugate
- Geometric Form Closed

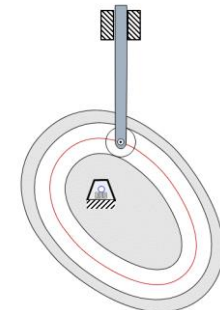
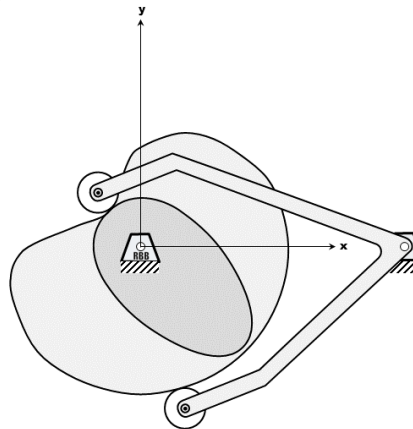

CAM Nomenclature

- **Trace Point** - the point of a fictitious **Knife-Edge** follower
 - used to generate the **pitch curve**
 - in the case of the roller follower it is at the center of the roller
- **Pitch Curve** - path generated by the **trace point** as the follower is rotated about the **CAM**

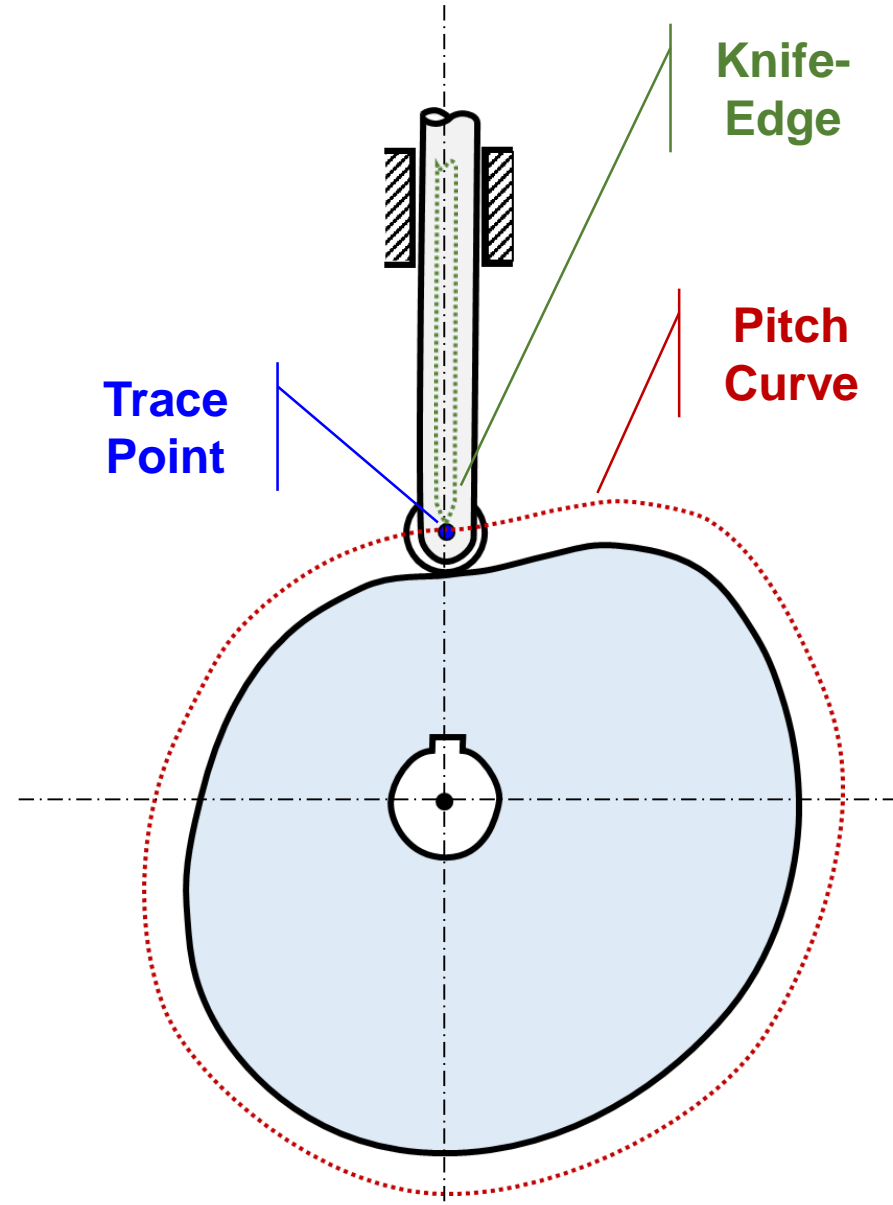

CAM Nomenclature

- **Pressure Angle** – the angle at any point between the normal to the **pitch curve** and the instantaneous direction of the follower motion
- **Pitch Point** – point on the CAM Pitch Curve that has the **LARGEST** Pressure Angle

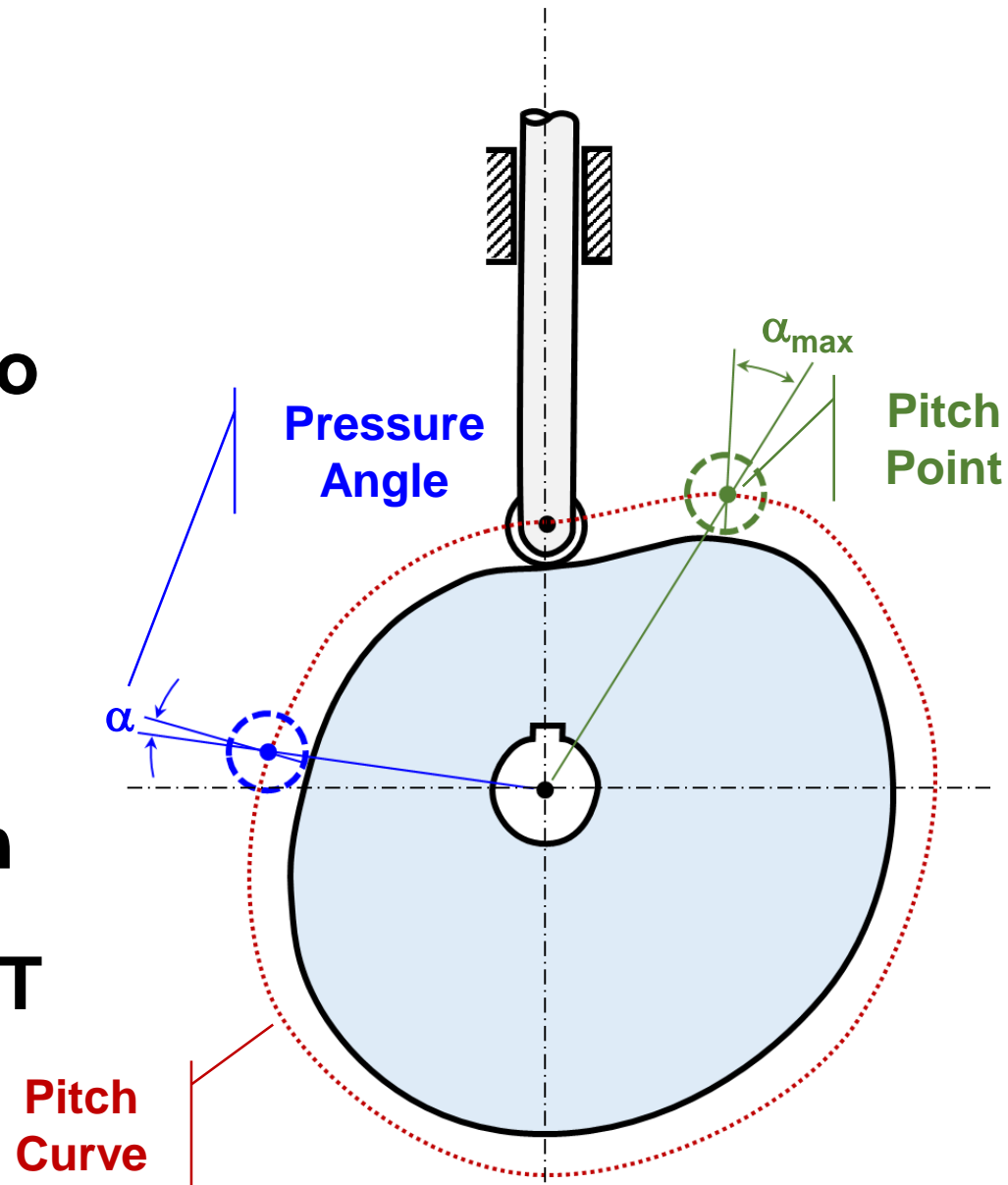

CAM Nomenclature

- **Working Curve or CAM Profile** – surface of a CAM in contact with the follower
 - for the knife-edge follower of the plate CAM, the pitch curve and the working curve coincide
 - in a closed or grooved CAM there is an inner profile and an outer working curve

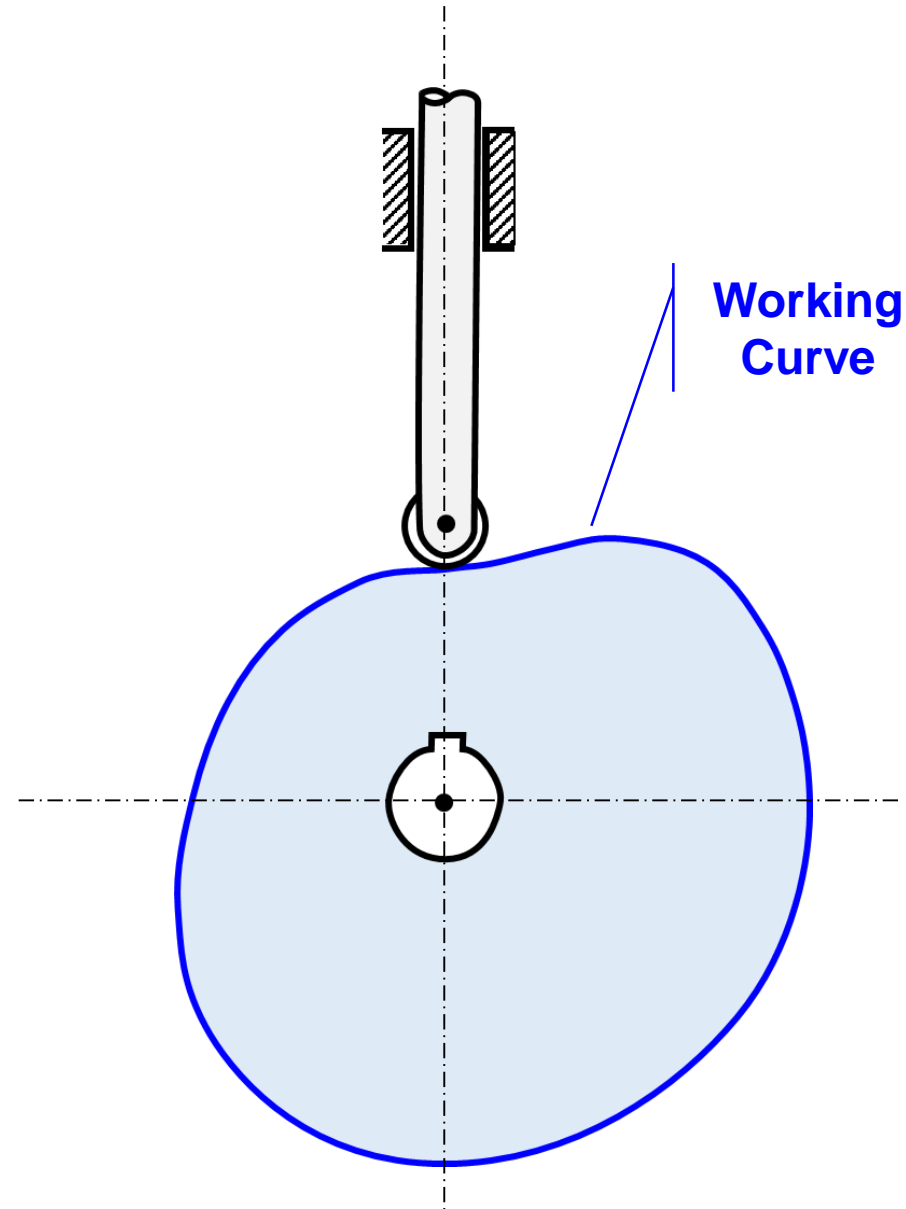

CAM Nomenclature

- **Pitch Circle** – a circle from the CAM center through the **Pitch Point**
 - pitch circle radius is used to calculate a CAM of minimum size for a given pressure angle
- **Prime Circle** – smallest circle from the CAM center through the pitch curve

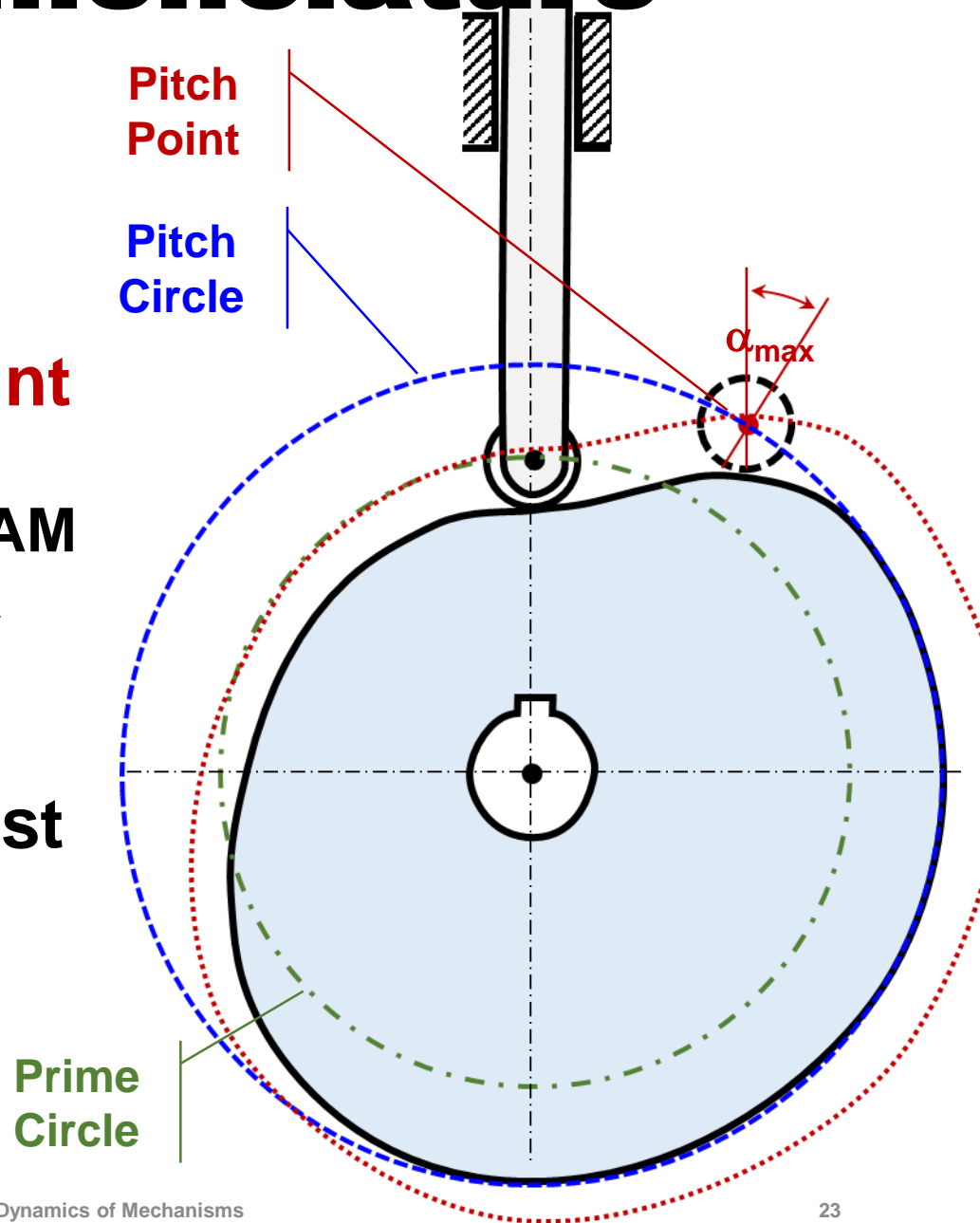

CAM Nomenclature

- **Major Circle** – largest circle from the cam center to the pitch curve
- **Base Circle** – smallest circle that can be drawn tangent to the cam surface concentric with the camshaft.

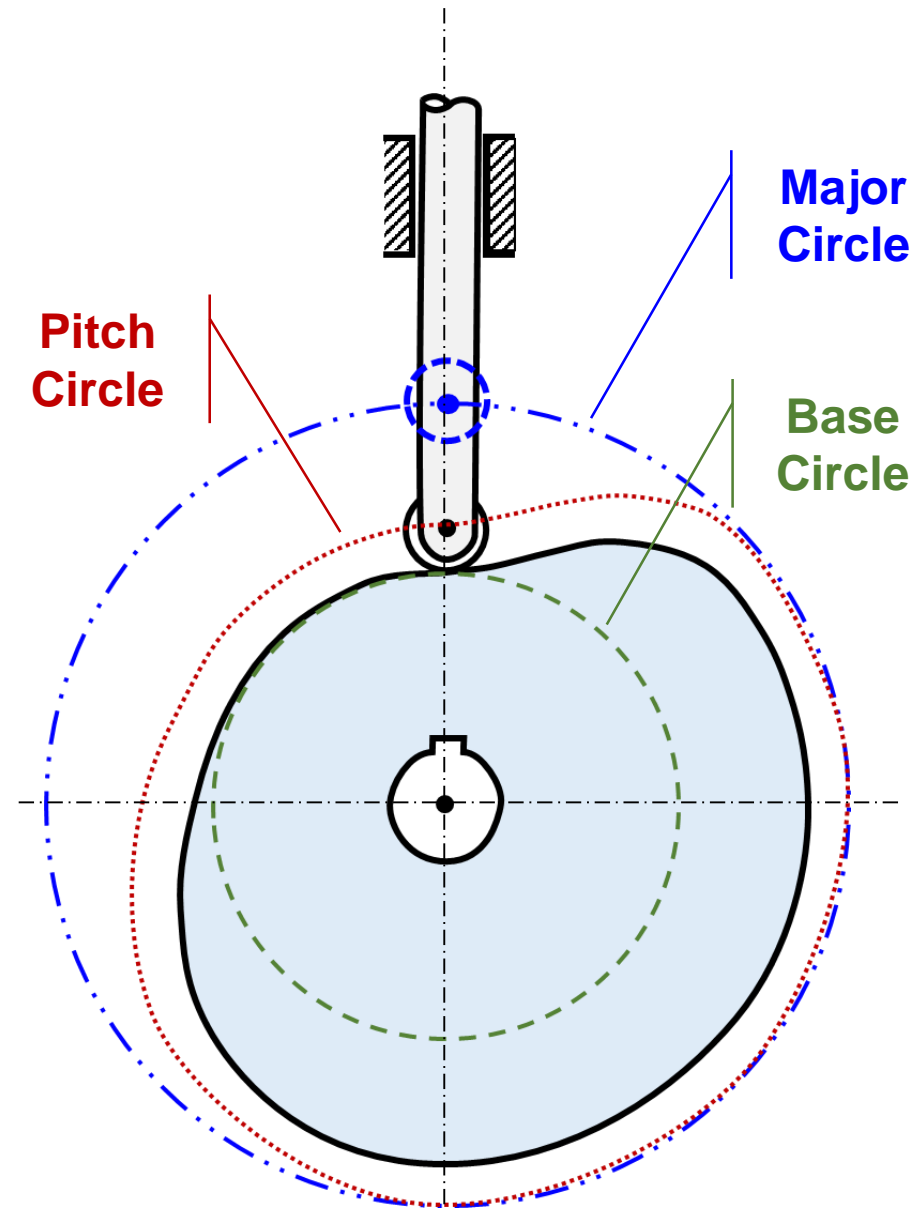

CAM Nomenclature

- **Follower Displacement, s** – the position of the follower from a specific zero or rest position **in relation to time**, measured in seconds, or some fraction of the machine cycle
- **Stroke or Throw, s_{max}** – the greatest distance through which the follower moves.

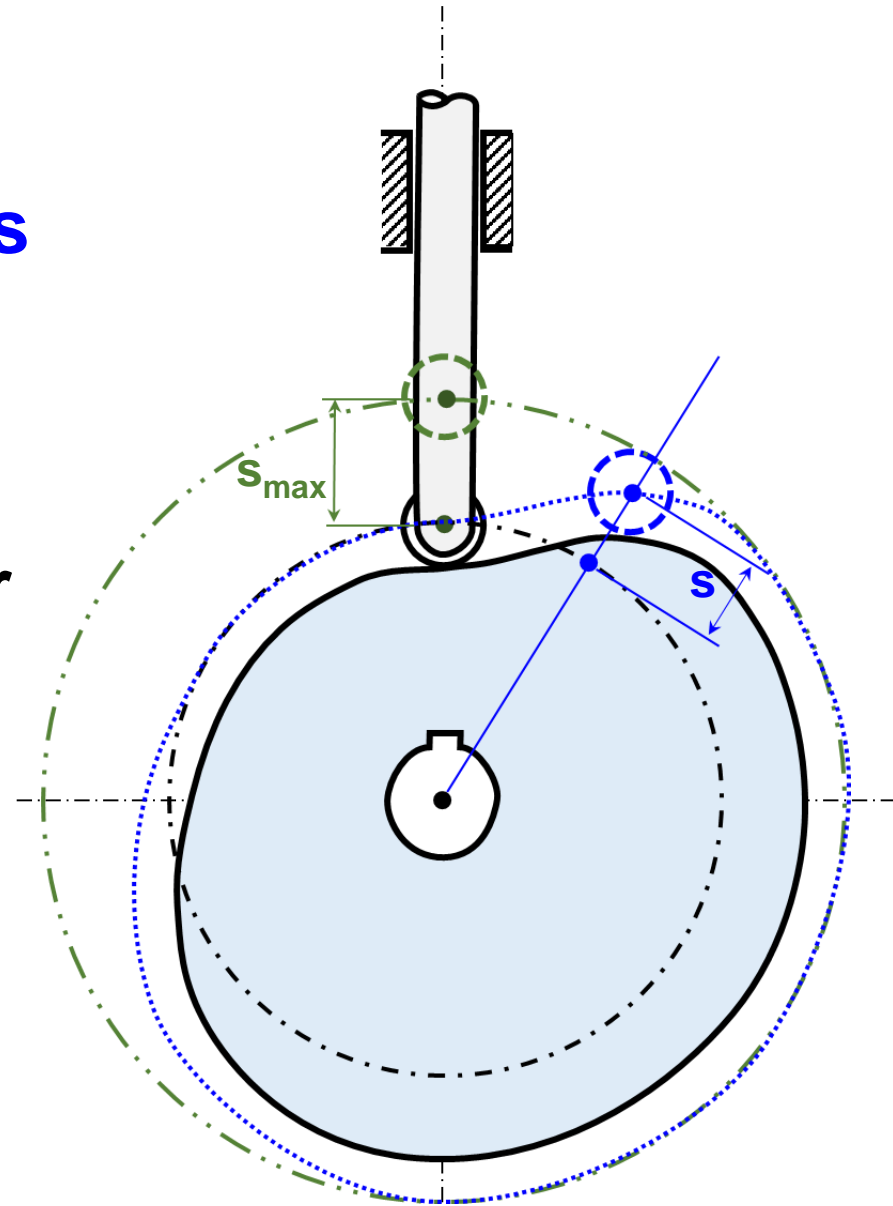

CAM Nomenclature

- **Transition Point** – the position of maximum velocity where acceleration changes from positive to negative
 - force on the follower changes direction
 - in a closed CAM this is some times referred to as the crossover path
 - due to the reversing of acceleration
 - follower leaves on cam profile
 - crosses over to the opposite or conjugate CAM profile

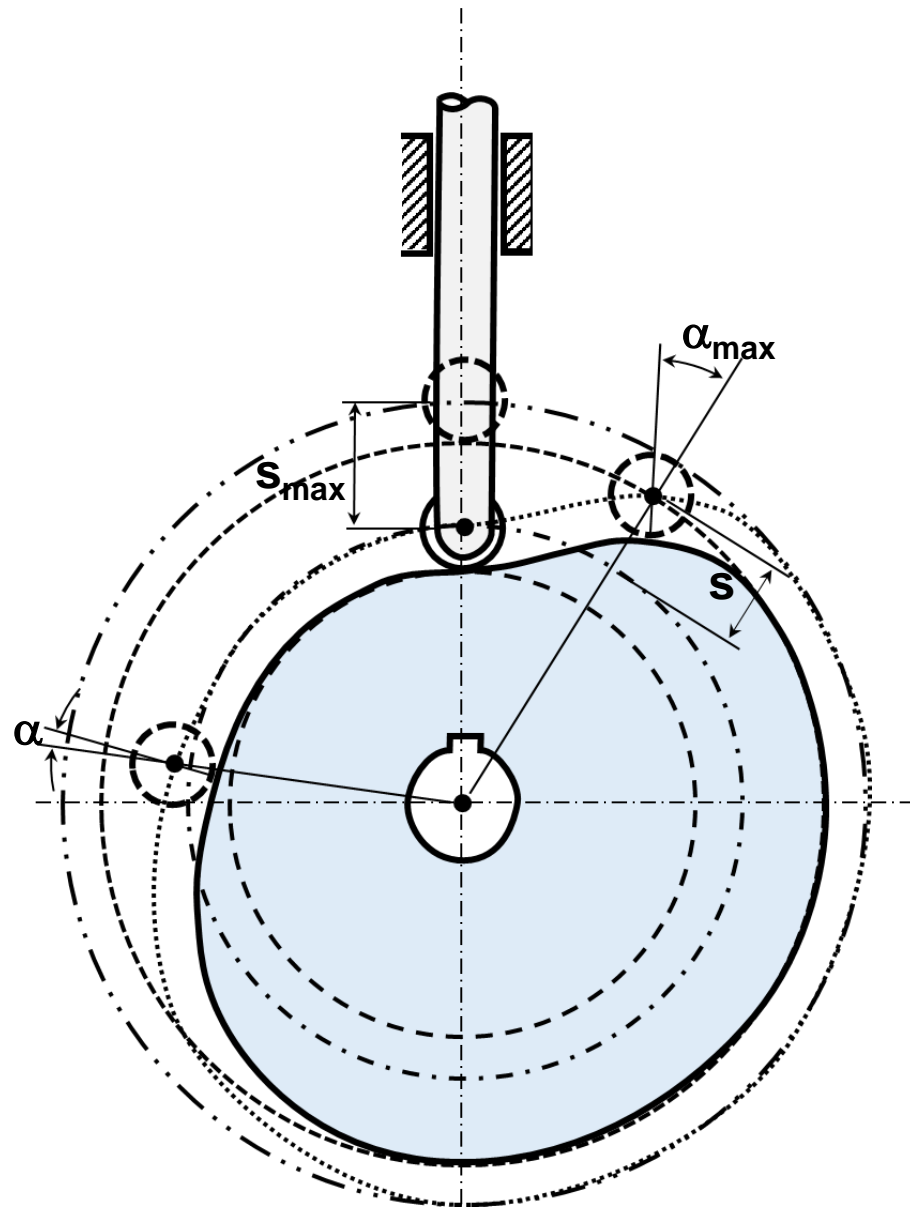

Design Considerations

- **Motion Specifications**

- **Develop a complete timing diagram**

- proper spacing
 - place in time cycle
 - relation to the motion specifications of the mechanism

- **A good CAM profile is one that has the lowest maximum acceleration**

- compromise must be made with other optimizing parameters

Design Considerations

- **Working Forces**

- **useful work done by the mechanism**
 - **may augment or reduce the other forces in the system**

- **Inertia or D'Alembert Forces**

- **product of the mass and the acceleration of the follower system**
- **more critical at high speed than at low**

Design Considerations

- **Impact Forces**

- **caused by separation between the CAM and roller surface**
- **Friction Force**

CAM Follower Design

- First step is to define the follower displacement

- Linearize or unwrap the CAM

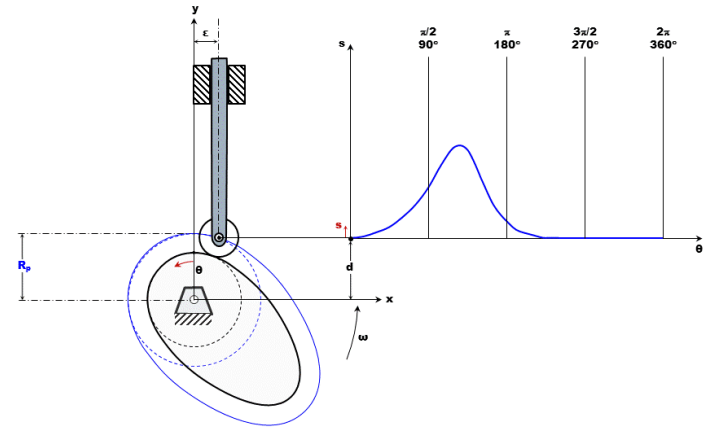

- Independent variable time

- $\theta = \omega \cdot t$

$y = y(\theta) \equiv$ follower motion

$$v = y'(\theta) = \frac{dy}{d\theta}$$

$$a = y''(\theta) = \frac{d^2 y}{d\theta^2}$$

$$j = y'''(\theta) = \frac{d^3 y}{d\theta^3}$$

RBB

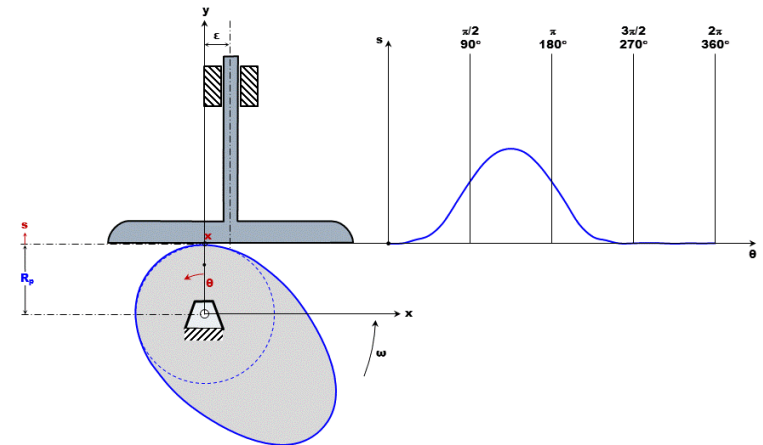

RBB

Relationship Between Functions of t (time) and θ

$$\theta = \omega \cdot t$$

$s = h \equiv$ Follower Displacement

$$v = \dot{s} = \frac{ds}{dt} = \frac{ds}{d\theta} \cdot \frac{d\theta}{dt} = \frac{ds}{d\theta} \cdot \omega = s' \cdot \omega \quad \Rightarrow \quad s' = \frac{\dot{s}}{\omega}$$

$$a = \ddot{s} = \frac{dv}{dt} = \frac{d\dot{s}}{dt} = \frac{d(s' \cdot \omega)}{dt} = \frac{ds'}{d\theta} \cdot \frac{d\theta}{dt} \cdot \omega = s'' \cdot \omega^2 \quad \Rightarrow \quad s'' = \frac{\ddot{s}}{\omega^2}$$

$$j = \ddot{\dot{s}} = \frac{da}{dt} = \frac{d\ddot{s}}{dt} = \frac{d(s'' \cdot \omega^2)}{dt} = \frac{ds''}{d\theta} \cdot \frac{d\theta}{dt} \cdot \omega^2 = s''' \cdot \omega^3 \quad \Rightarrow \quad s''' = \frac{\ddot{\dot{s}}}{\omega^3}$$

Types of Motion Constraints

- **Critical Extreme Position (CEP)**
 - Design specifications define start and finish position of the follower
 - Design specifications do NOT specify path between start and finish positions
- **Critical Path Motion (CPM)**
 - Path motion and/or one or more of its derivatives are defined over all or part of the interval of motion
 - Analogous to Function Generation in a linkage

Types of Motion Programs for Critical Extreme Path

- Rise-Fall (RF)

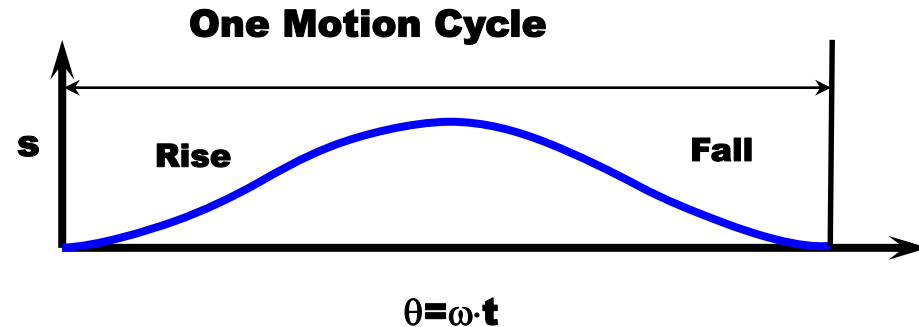

- Rise-Fall-Dwell (RFD)

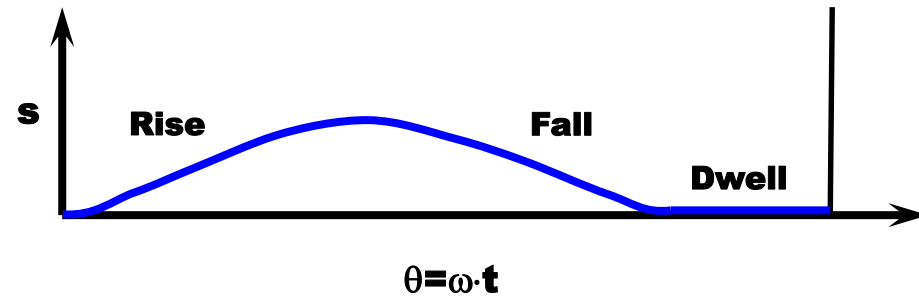

- Rise-Dwell-Fall-Dwell (RDFD)

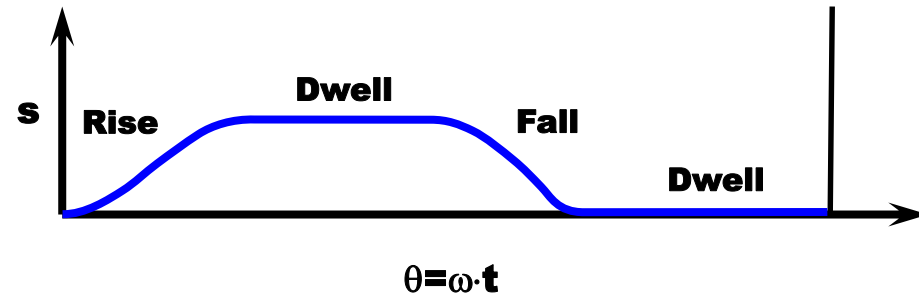

Examples of Critical Extreme Path

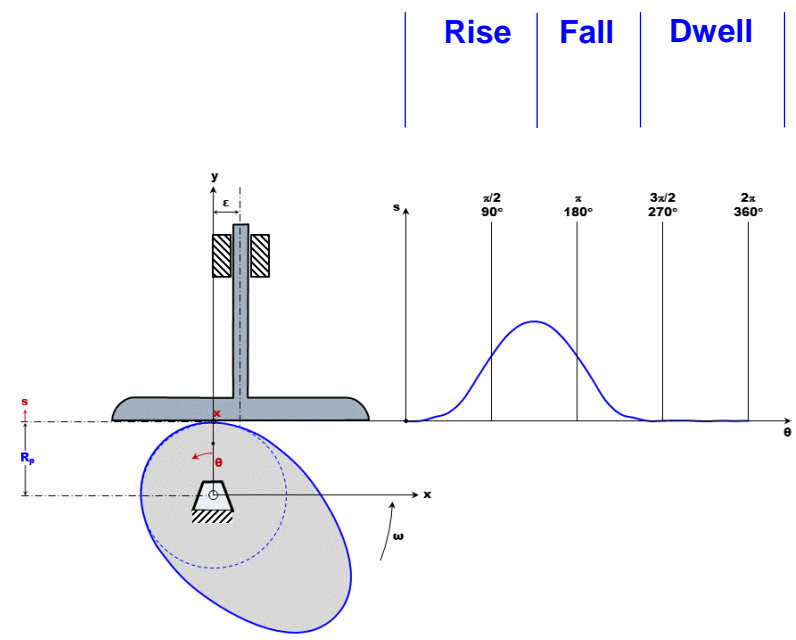
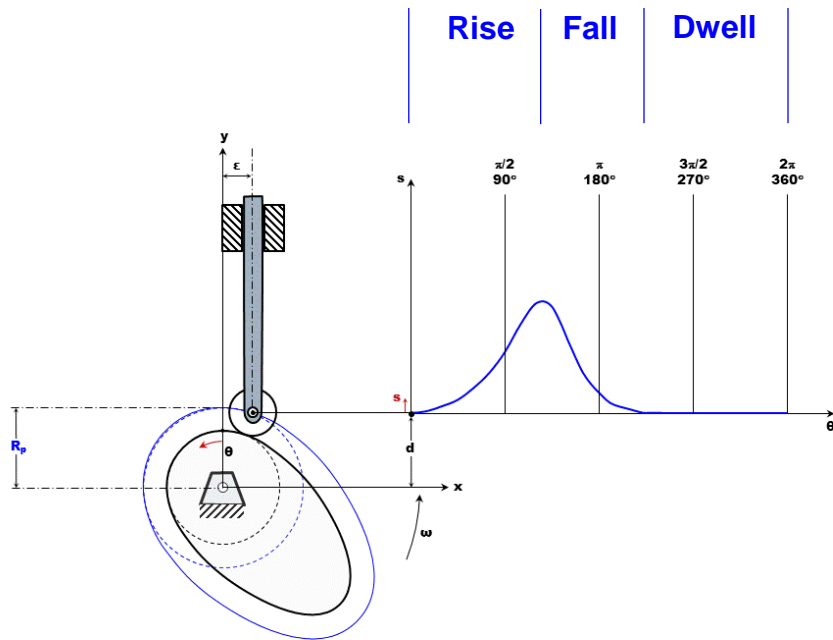

RBB

RBB

Fundamental Laws of CAM Design

- The CAM function must be continuous through the first and second derivatives.
 - Jerk must be **finite**
- Implications to real systems
 - Followers have mass
 - Acceleration leads to inertial force
 - Acceleration leads to contact stress
 - Abrupt changes in acceleration leads to:
 - Noise
 - Surface wear
 - Eventual failure

Timing Diagram

