

Introduction to Isomers and Linkage Synthesis

- Linkage Synthesis Overview
- Isomers

Number Synthesis

- Determining the number and order of links and joints necessary to produce motion of a particular mobility

- Link order
 - Number of Binary (B), Ternary (T), Quaternary (Q), Pentagonal (P), Hexagonal (H) links
 - $L = B + T + Q + P + H$
≡ total number of links

Link Order

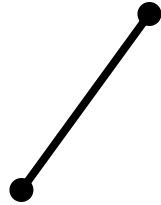

Binary

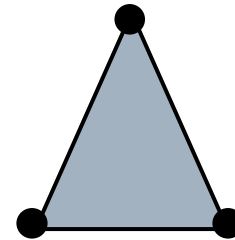

Ternary

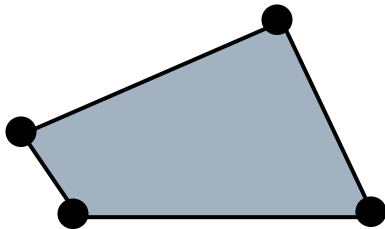

Quaternary

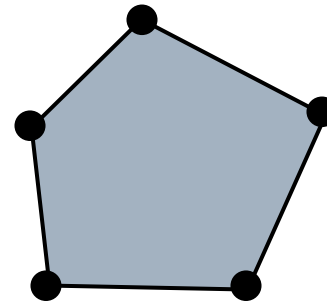

Pentagonal

Isomer Joint Type Nomenclature

- Dashed Line: Imaginary Link
- R: Revolute Joint
 - Pin Joint
 - Hinged connection
- P/T: Lower Pair Sliding Joint
 - Prismatic Joint
 - Relative Translational Motion
- C: Center of Curvature
- B: Base Point

Grübler/Kutzbach Criterion

$$M = 3 \cdot (L - 1) - 2 \cdot j_1 \quad (\text{Grübler})$$

$$M = 3 \cdot (L - 1) - 2 \cdot j_1 - j_2 \quad (\text{Kutzbach})$$

- **M=1**
 - **Mechanism can be driven by a single input direction**
- **M=2**
 - **Two separate input motions are necessary to produce constrained motion for the mechanism**
 - **Differential Mechanism**
- **M=0**
 - **Motion is impossible and the mechanism is a structure**
 - **Exact Constraint**
- **M=-1**
 - **Redundant constraint**
 - **Pre-Load**

Number Synthesis Uses Grüber's Equation

- Grüber's Criterion: $M=3(L-1)-2J$
 - A half joint is just a full joint with an imaginary link through the base points
 - Base points are the location of the center of curvatures

- For Linkages with Full Joints
 - $L=B+T+Q+P+H+\dots$
 - $L-(M+3)=T+2Q+3P+4H+\dots$

- DoF Must Be Uniformly Distributed

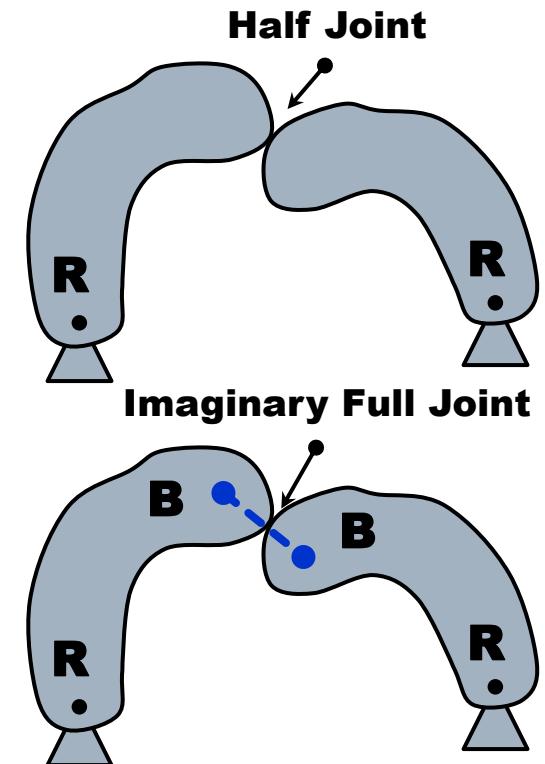
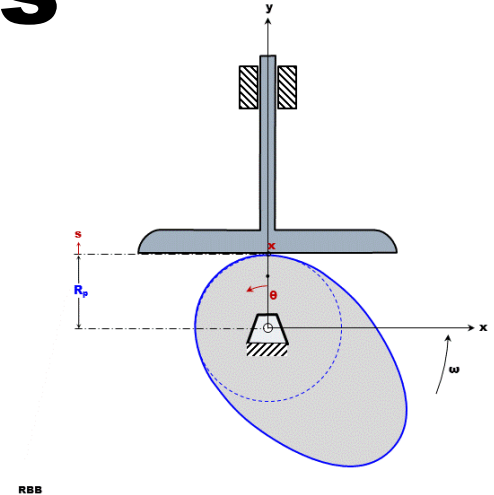

Uniformly Distributed DoF

Basic Links
To Work With

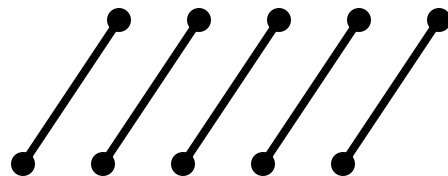

B=5

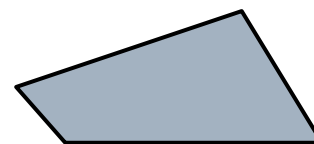

Q=1

Isomers of this link
combination
contribute nothing
new for M=+1
synthesis use

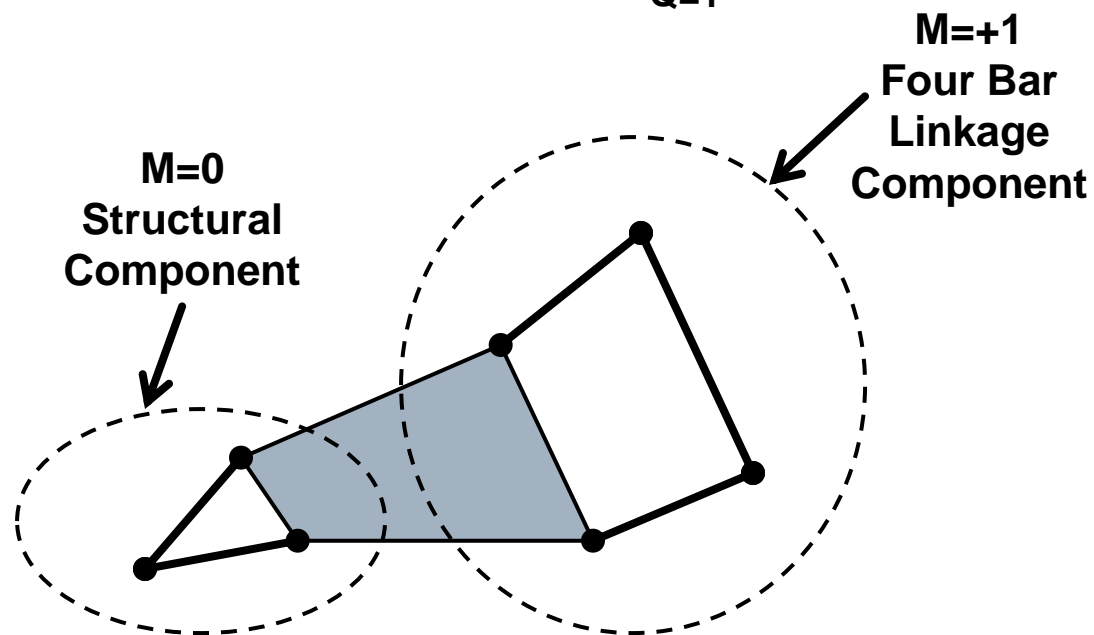

Implication of Grübler's Equation

$$J = \frac{3}{2} \cdot L - \frac{(M + 3)}{2}$$

- If all joints are full joints
 - An **ODD** number of **DOF** (M) requires an **EVEN** number of links (L)
 - An **EVEN** number of **DOF** (M) requires an **ODD** number of links (L)

Considering $M=+1$ Continued L must be even: 4

□ $M=+1, L=4$

■ $4 = B + T + Q + P \Rightarrow 4 = B$

$T + 2 \cdot Q + 3 \cdot P = 0 \quad T=Q=P=0$

■ $J = \frac{3}{2} \cdot 4 - \frac{(1+3)}{2} = 4$

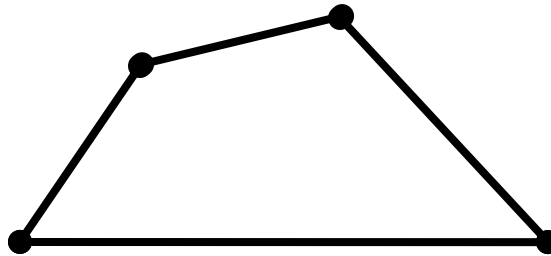

Synthesis of Mechanical Devices From The Isomer

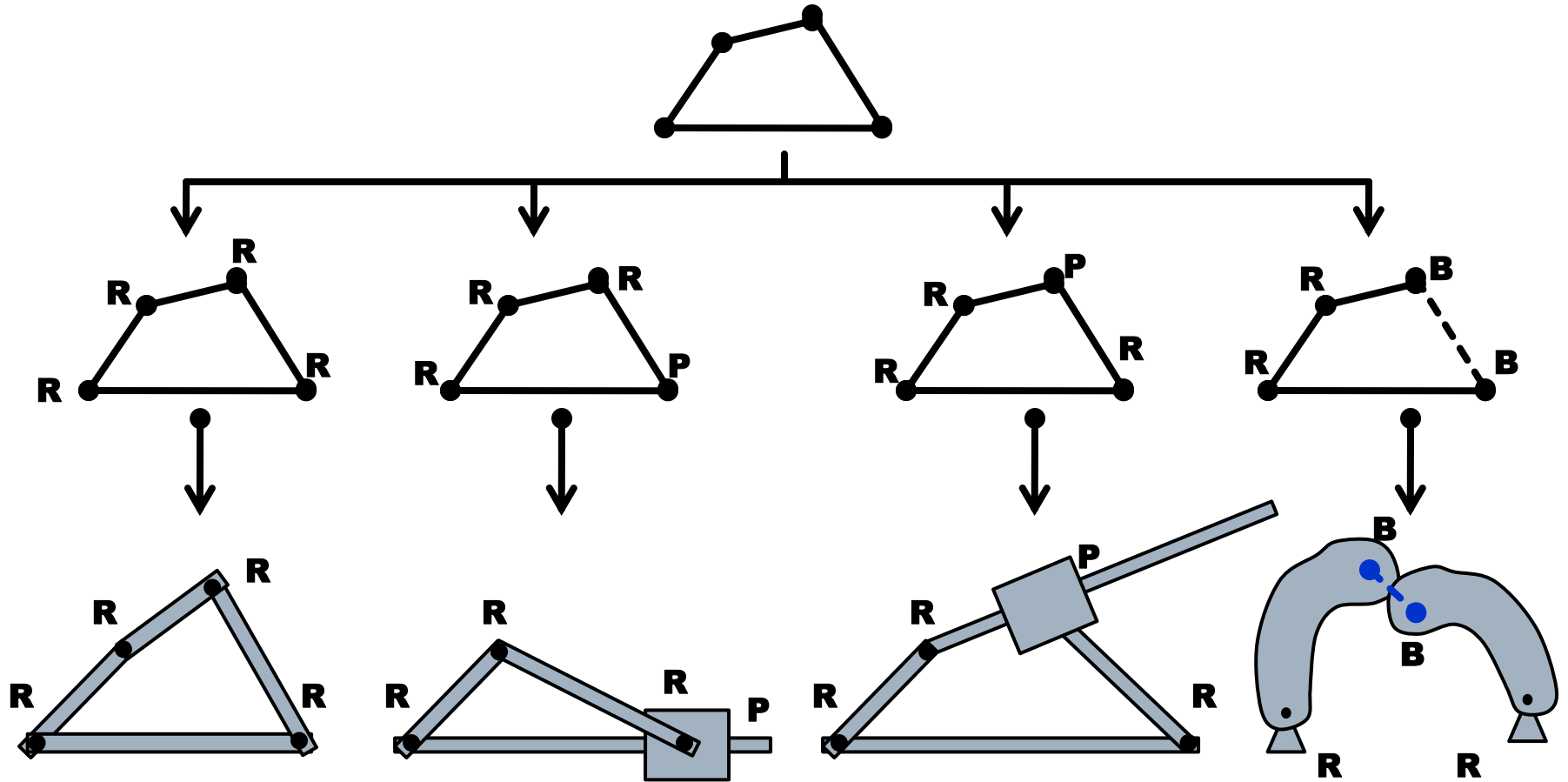

Case III – No Acceptable Isomers

M=+1, L=6, P=0, Q=1, T=0, B=5

Basic Links
To Work With

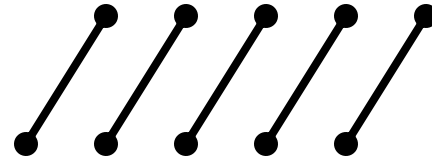

B=5

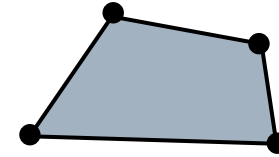

Q=1

Can Not Connect
Fifth Link and Have
Uniformly Distributed
M=+1

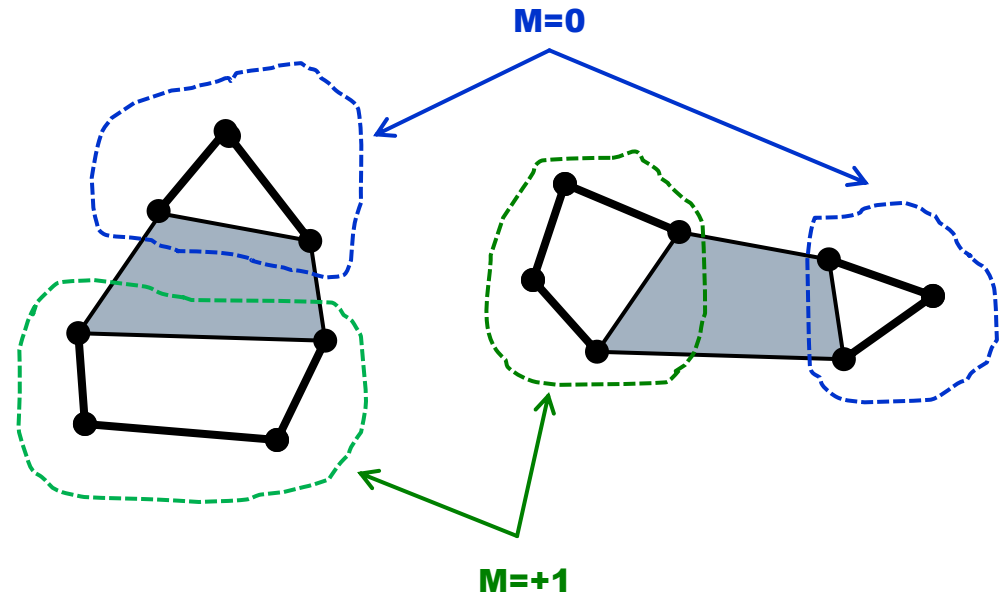

Case II – 2 Acceptable Isomers

M=+1, L=6, P=0, Q=0, T=2, B=4

Basic Links
To Work With

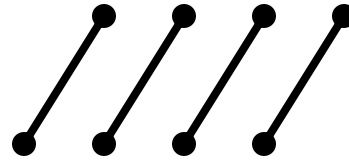

B=4

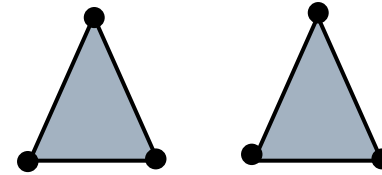

T=2

Unacceptable
Isomers for M=+1

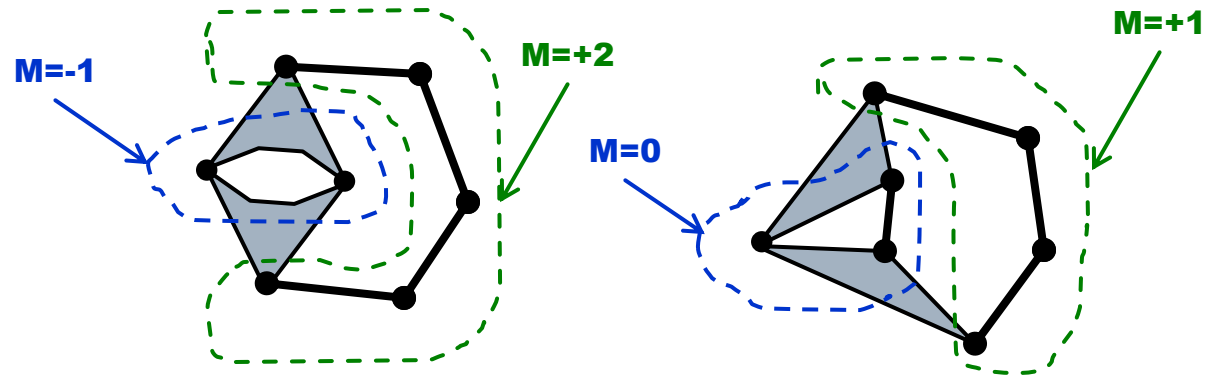

Acceptable
Isomers for M=+1

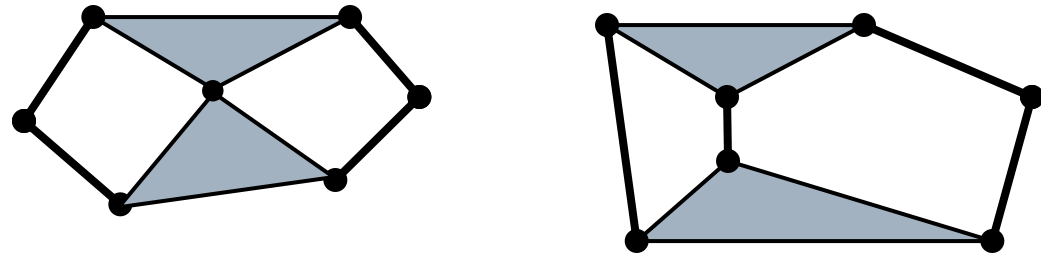

Link Combinations for Single Pin-Jointed Plane Linkages, $M=+1$

M	L	B	T	Q	P	Designation
+1	4	4	0	0	0	I
	6	4	2	0	0	II
	6	5	0	1	0	III
	8	4	4	0	0	IV
	8	5	2	1	0	V
	8	6	0	2	0	VI
	8	6	1	0	1	VII

M	L	B	T	Q	P	Designation
+1	4	4	0	0	0	I

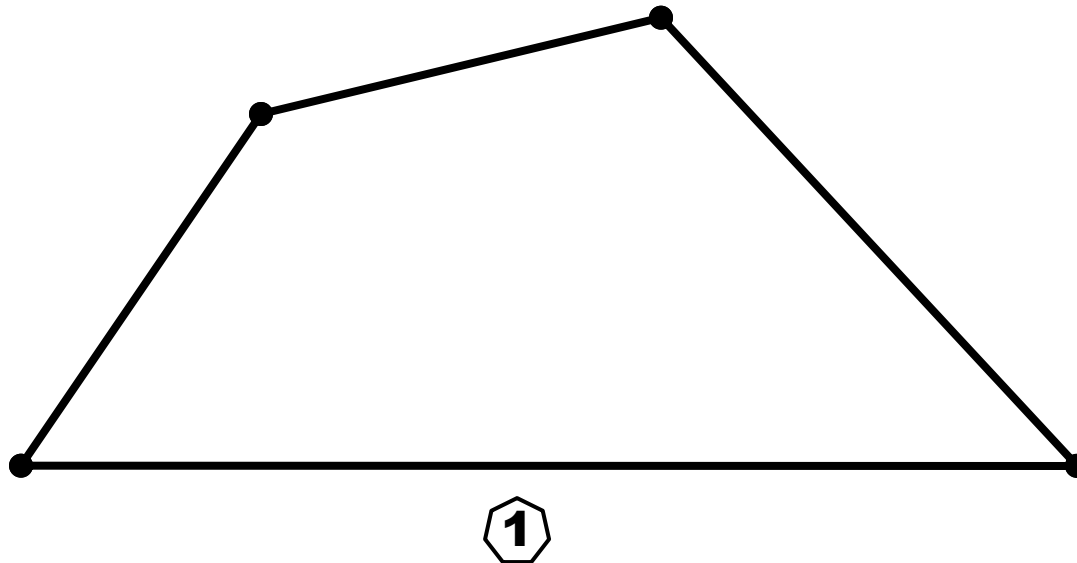

M	L	B	T	Q	P	Designation
+1	6	4	2	0	0	II

ESC104: Graphical Synthesis (RBB)

Watt's Linkage

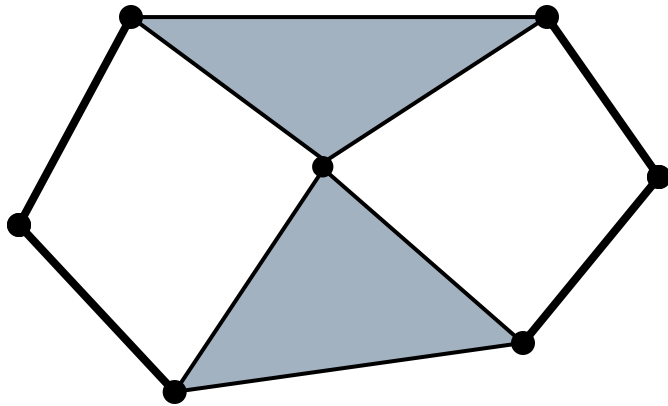

1

Stephenson's Linkage

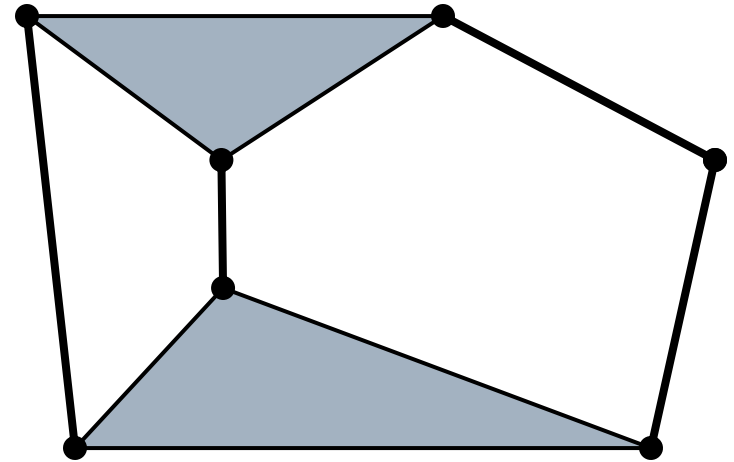

2

M	L	B	T	Q	P	Designation
+1	8	4	4	0	0	IV

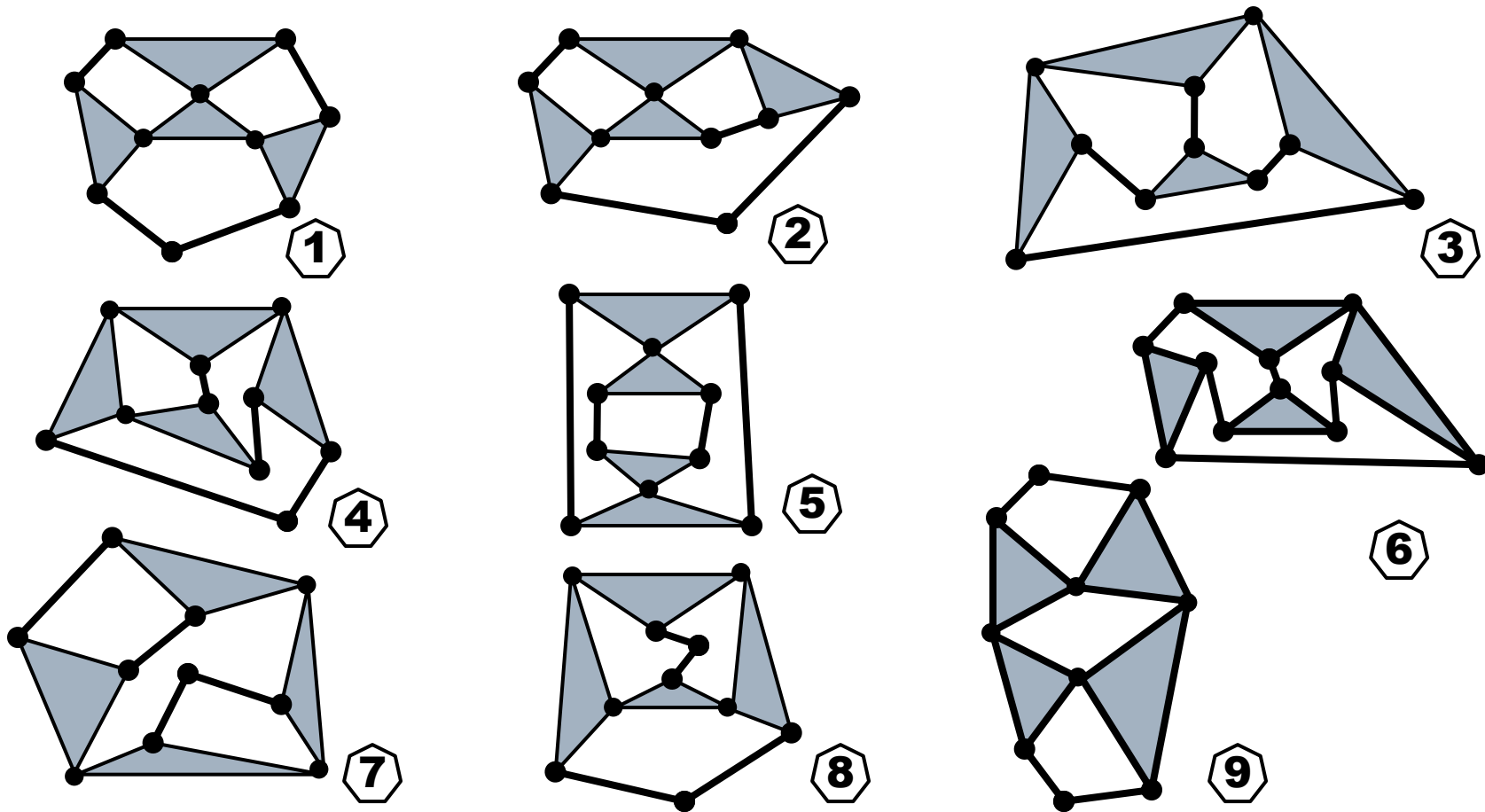

M	L	B	T	Q	P	Designation
+1	8	5	2	1	0	V

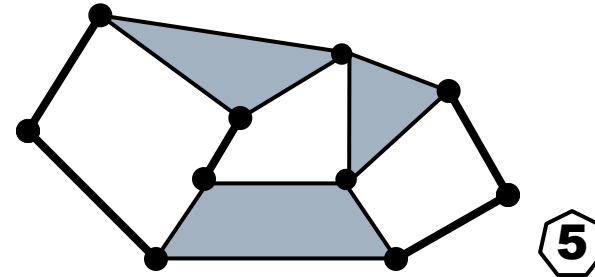
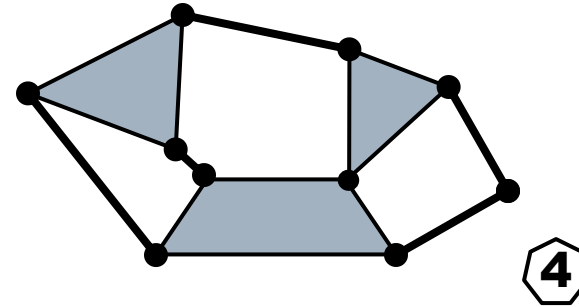
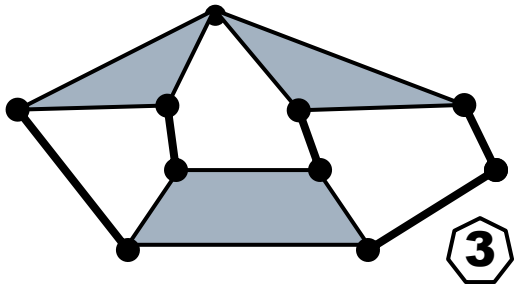
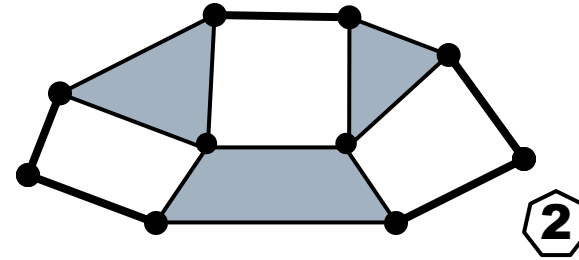
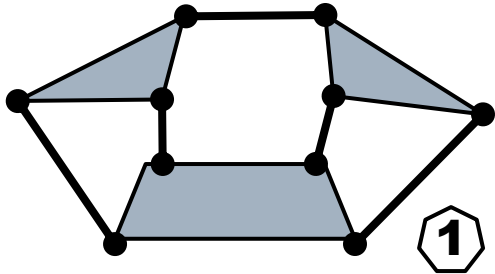

M	L	B	T	Q	P	Designation
+1	8	6	0	2	0	VI

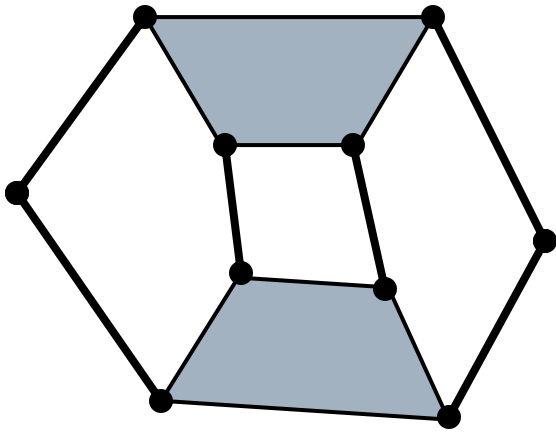

1

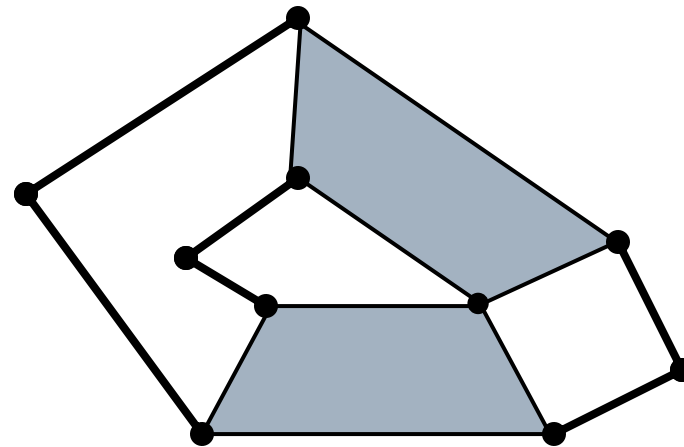

2

Link Combinations for Single Pin-Jointed Plane Linkages, $M=0$

M	L	B	T	Q	P	Designation
0	3	3	0	0	0	VIII
	5	3	2	0	0	IX
	5	4	0	1	0	X
	7	5	1	0	1	XI
	7	3	4	0	0	XII
	7	4	2	1	0	XIII
	7	5	0	2	0	XIV

M	L	B	T	Q	P	Designation
0	3	3	0	0	0	VIII

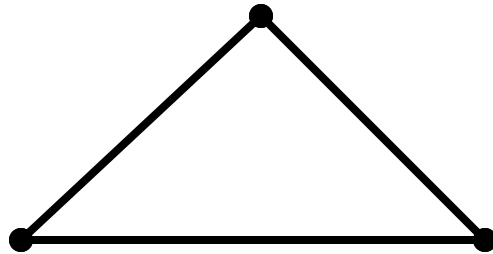

1

M	L	B	T	Q	P	Designation
0	5	3	2	0	0	IX

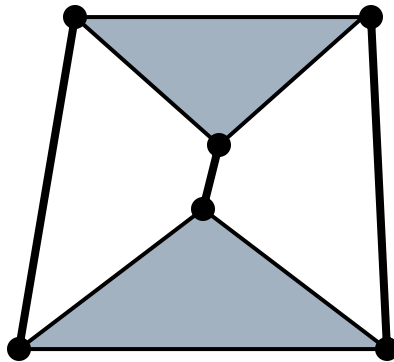

1

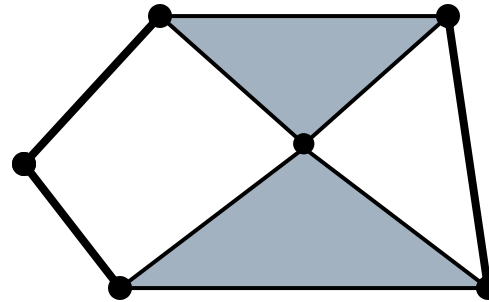

2

M	L	B	T	Q	P	Designation
0	5	4	0	1	0	X

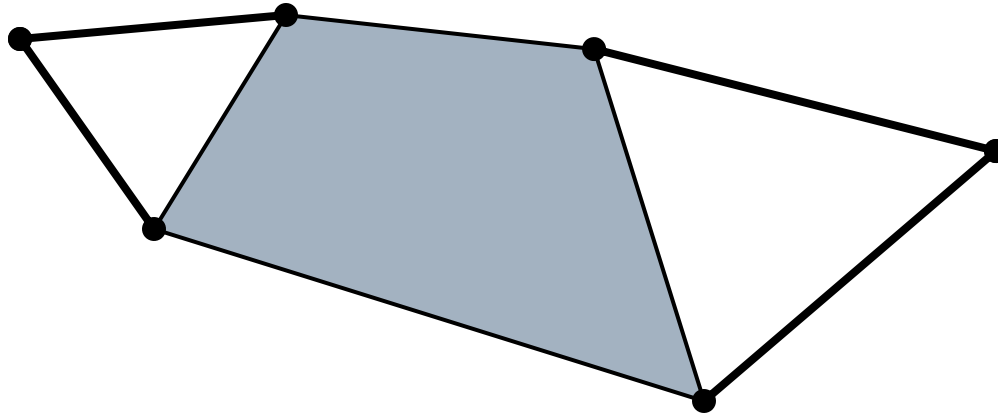

1

M	L	B	T	Q	P	Designation
0	7	5	1	0	1	XI

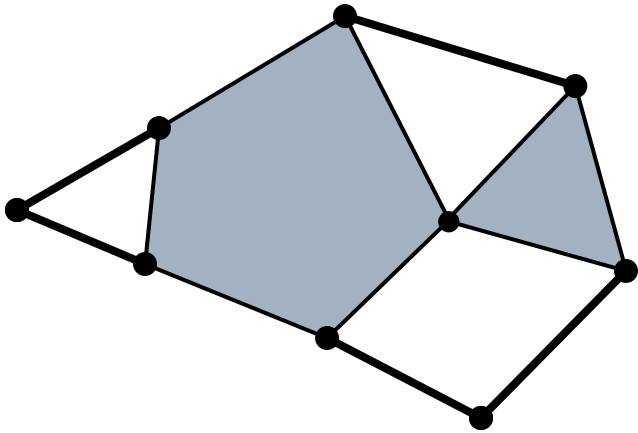

1

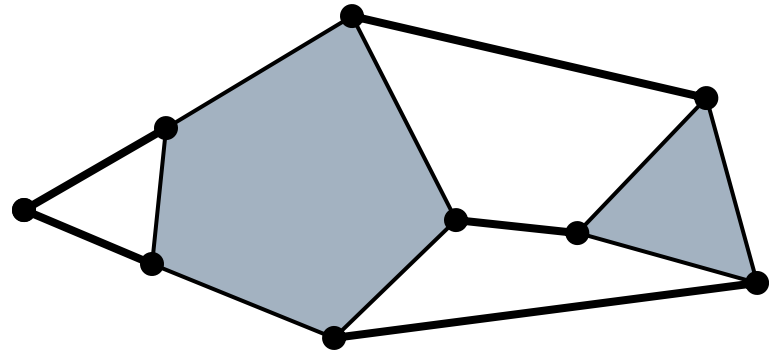

2

M	L	B	T	Q	P	Designation
0	7	3	4	0	0	XII

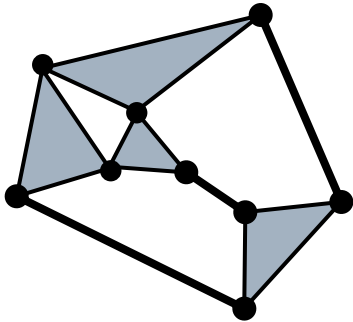

1

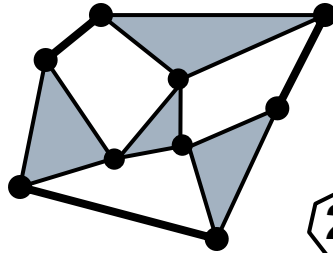

2

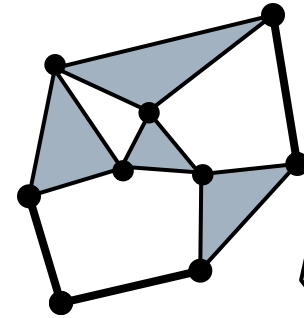

3

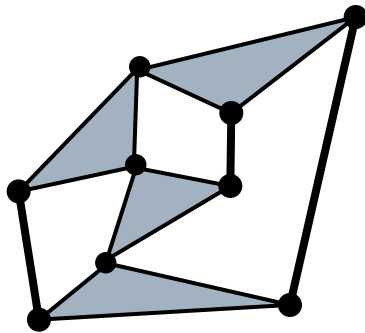

4

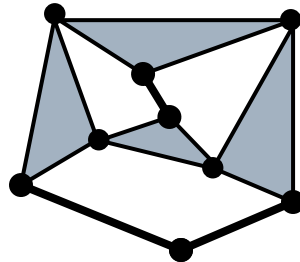

5

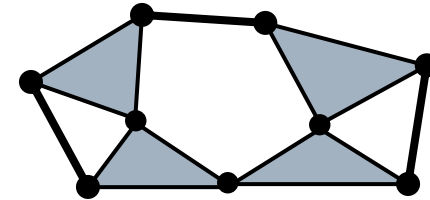

6

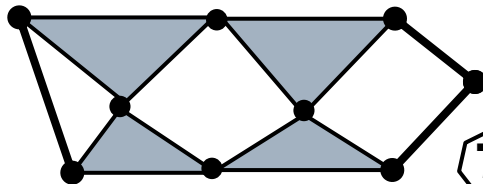

7

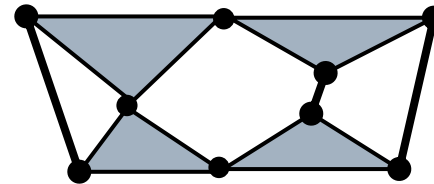

8

M	L	B	T	Q	P	Designation
0	7	4	2	1	0	XIII

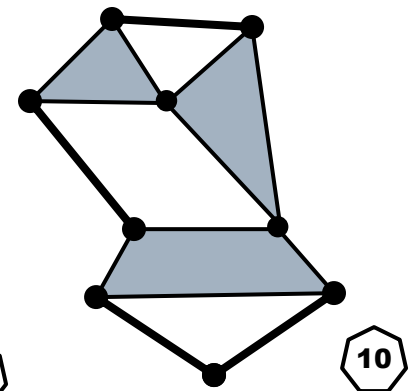
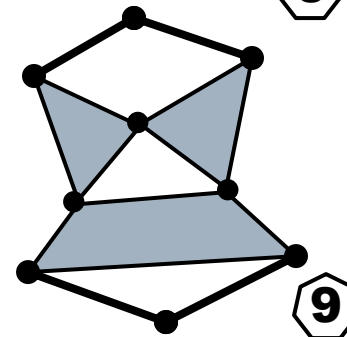
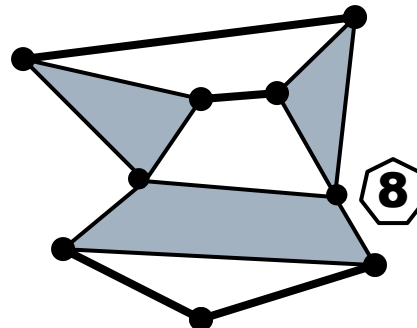
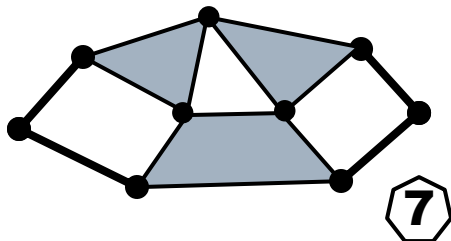
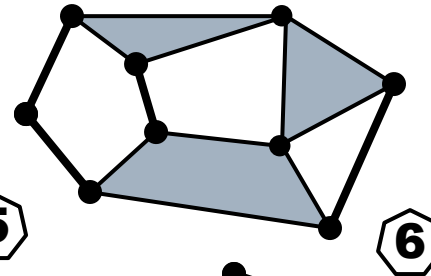
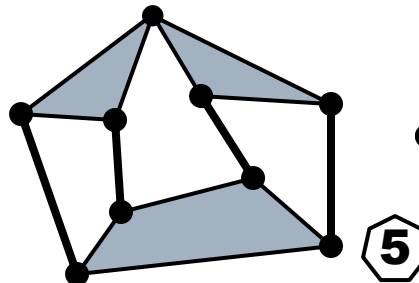
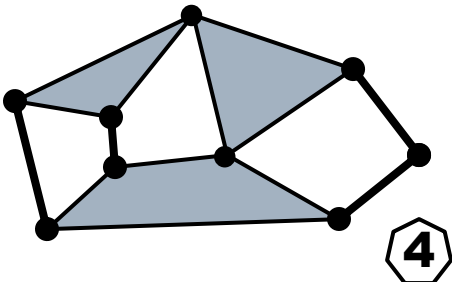
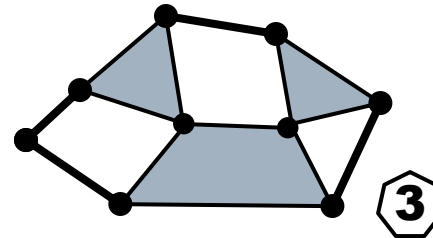
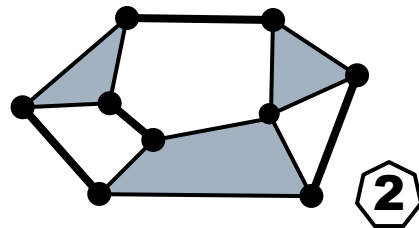
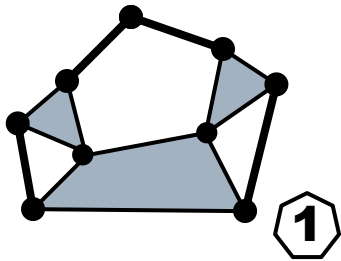

M	L	B	T	Q	P	Designation
0	7	5	0	2	0	XIV

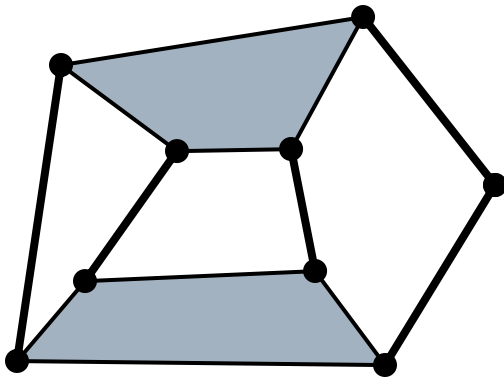

1

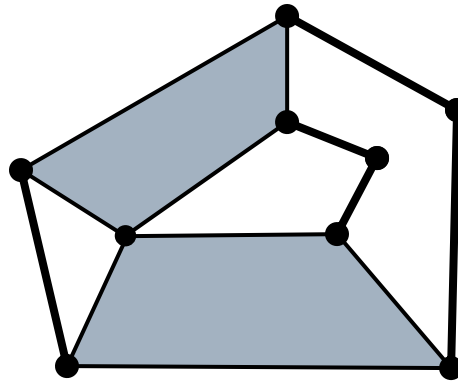

2

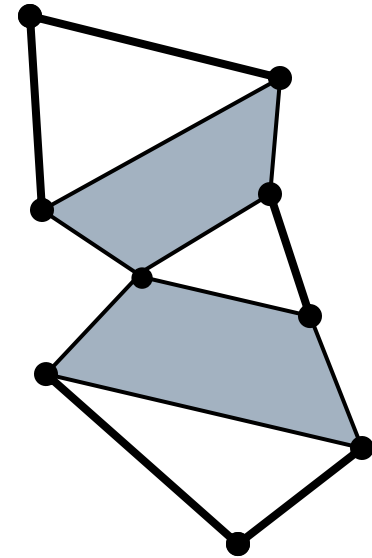

3

Link Combinations for Single Pin-Jointed Plane Linkages, $M=-1$

M	L	B	T	Q	P	Designation
-1	2	2	0	0	0	XV
	4	2	2	0	0	XVI
	4	3	0	1	0	XVII
	6	4	1	0	1	XVIII
	6	4	0	2	0	XIX
	6	3	2	1	0	XX
	6	2	4	0	0	XXI

M	L	B	T	Q	P	Designation
-1	8	6	0	0	2	XXII
	8	5	1	1	1	XXIII
	8	4	3	0	1	XXIV
	8	5	0	3	0	XXV
	8	4	2	2	0	XXVI
	8	3	4	1	0	XXVII
	8	2	6	0	0	XXVIII

M	L	B	T	Q	P	Designation
-1	2	2	0	0	0	XV

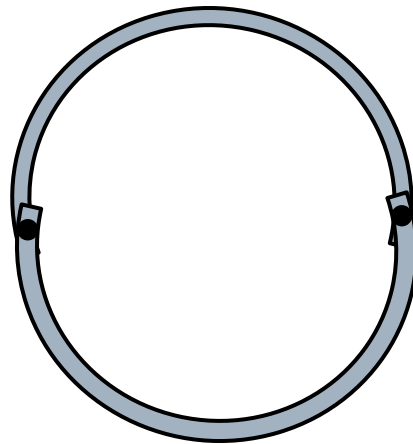

1

M	L	B	T	Q	P	Designation
-1	4	2	2	0	0	XVI

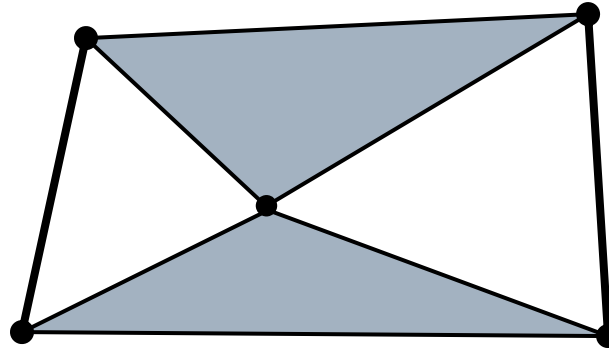

1

M	L	B	T	Q	P	Designation
-1	6	4	0	2	0	XIX

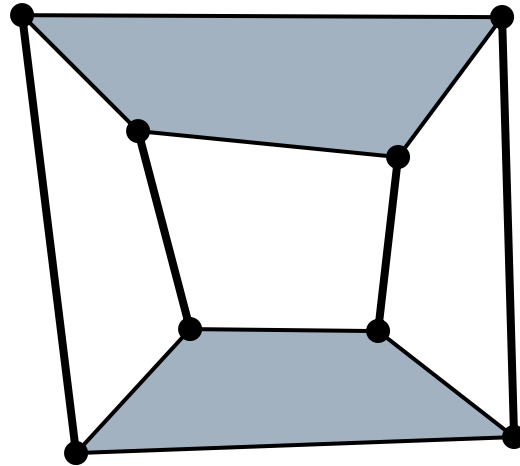

1

M	L	B	T	Q	P	Designation
-1	6	3	2	1	0	XX

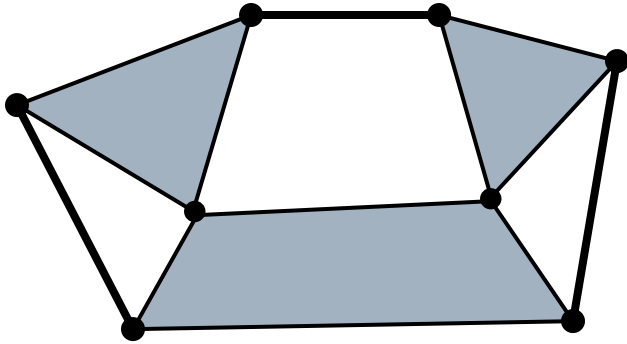

1

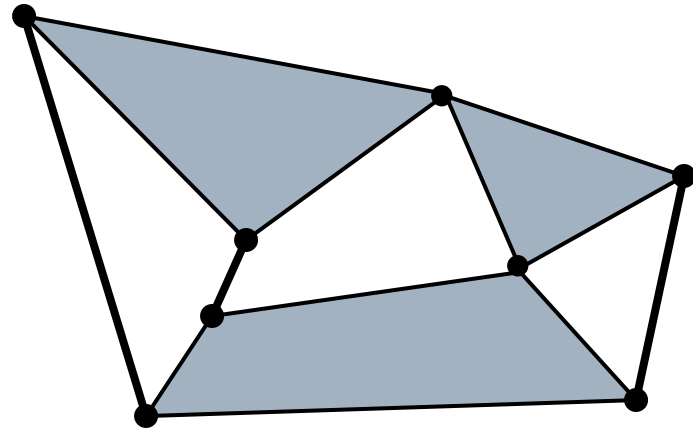

2

M	L	B	T	Q	P	Designation
-1	6	2	4	0	0	XXI

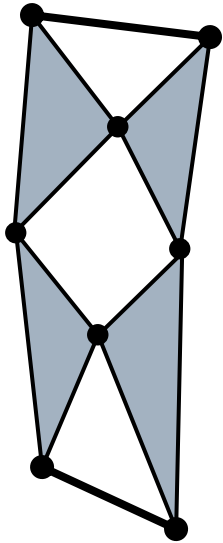

1

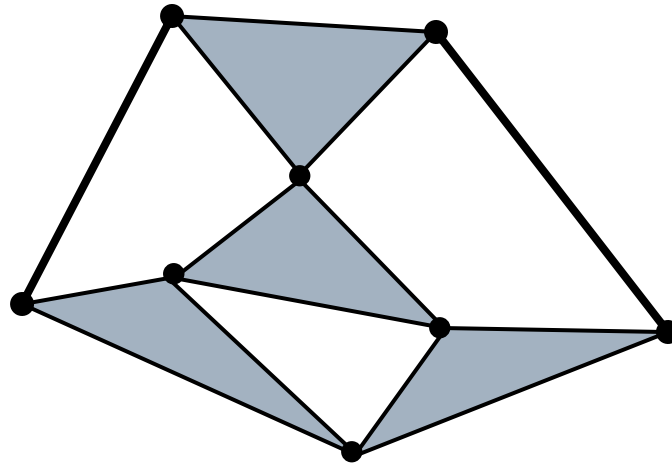

2

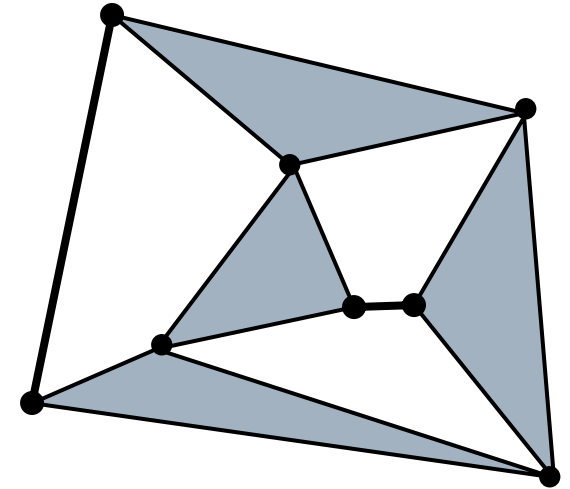

3

M	L	B	T	Q	P	Designation
-1	8	5	1	1	1	XXIII

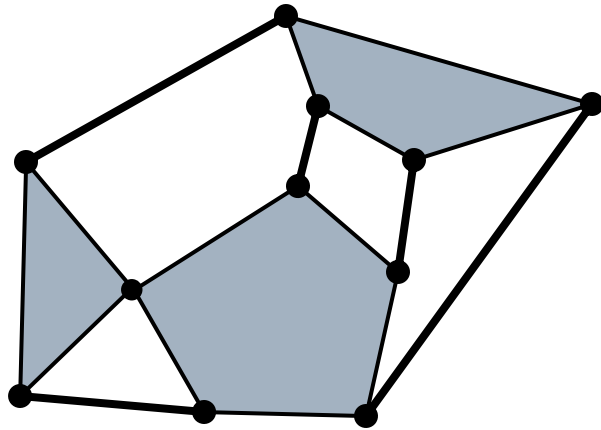

1

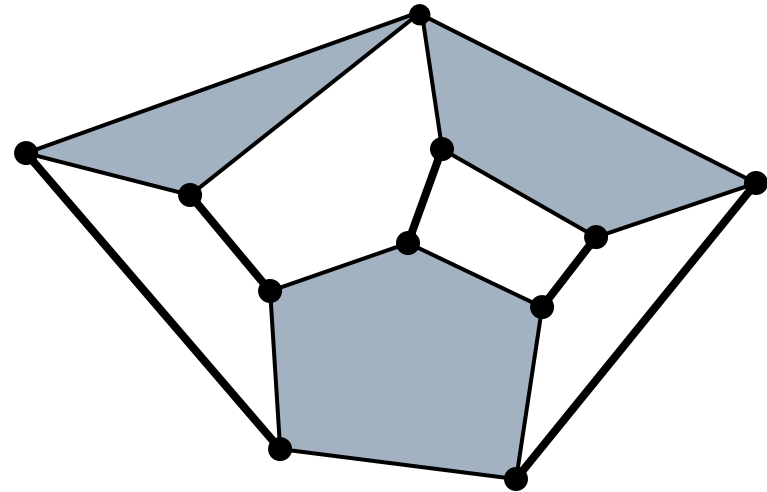

2

M	L	B	T	Q	P	Designation
-1	8	4	3	0	1	XXIV

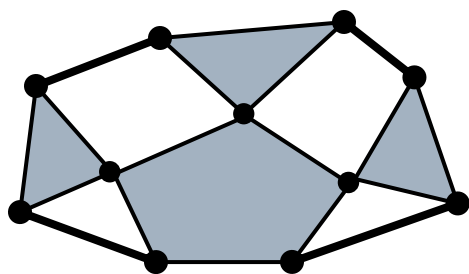

1

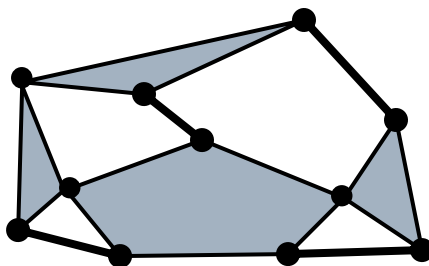

2

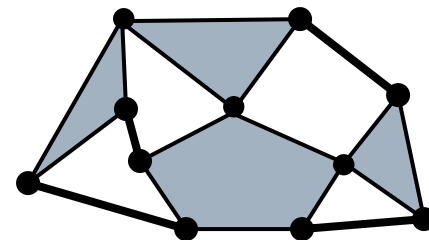

3

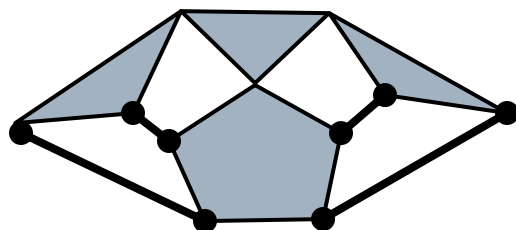

4

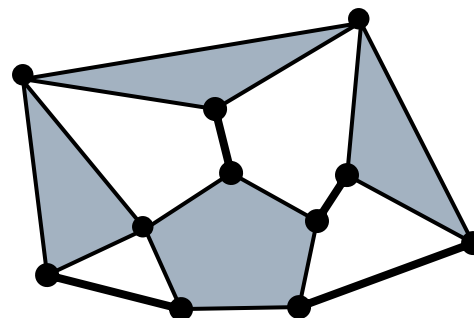

5

M	L	B	T	Q	P	Designation
-1	8	5	0	3	0	XXV

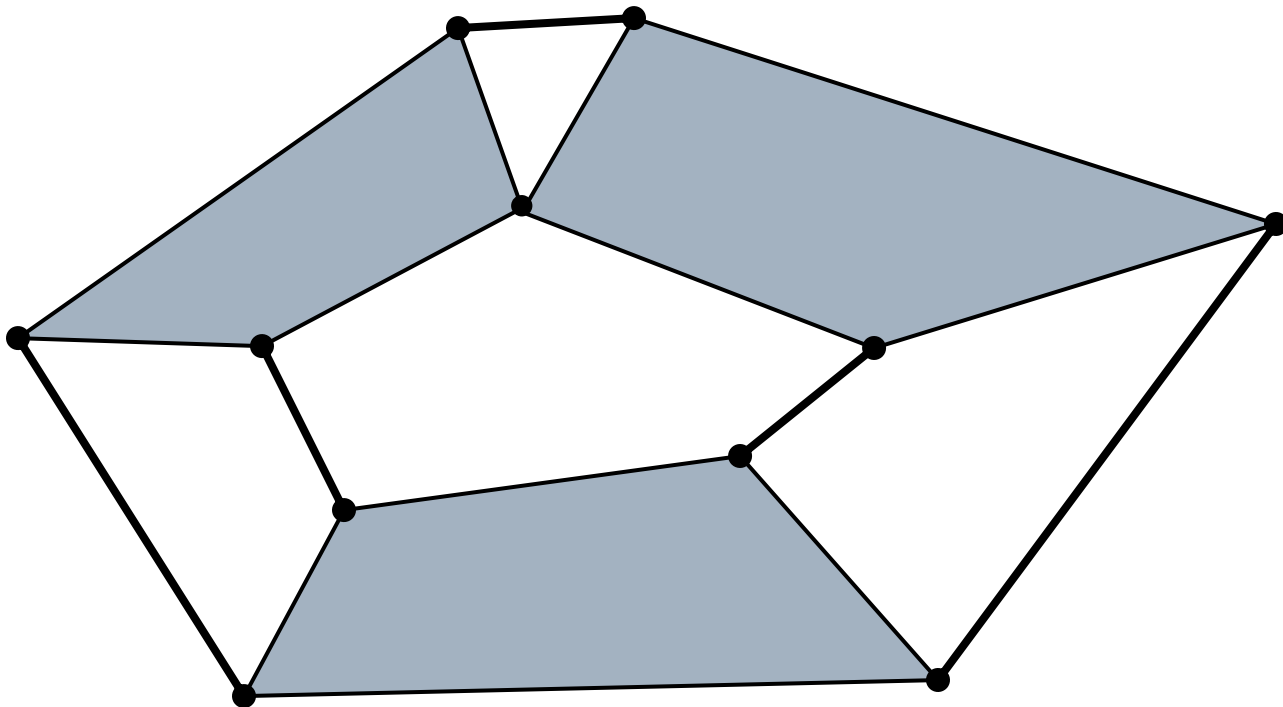

1

M	L	B	T	Q	P	Designation
-1	8	4	2	2	0	XXVI

(Plus 11 more not shown)

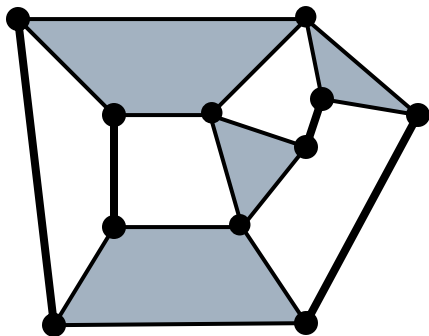

1

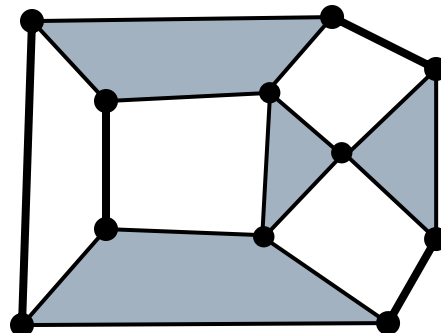

2

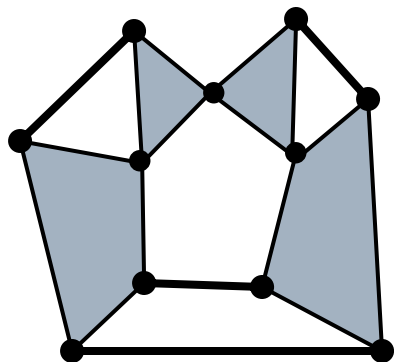

3

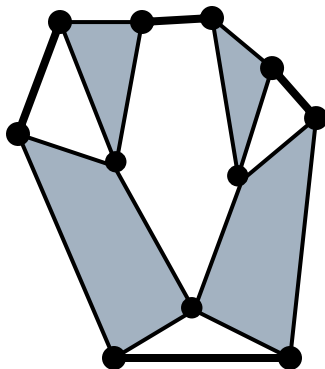

4

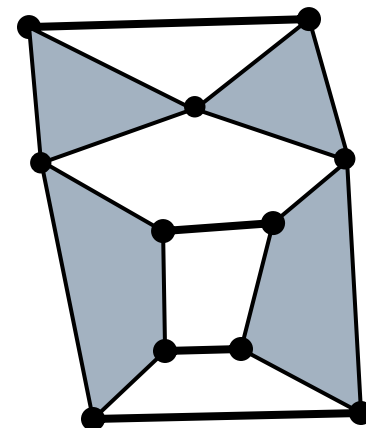

5

M	L	B	T	Q	P	Designation
-1	8	3	4	1	0	XXVII

(Plus 16 more not shown)

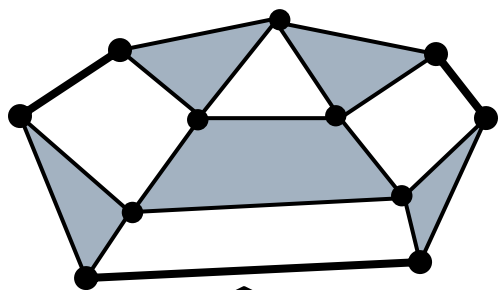

1

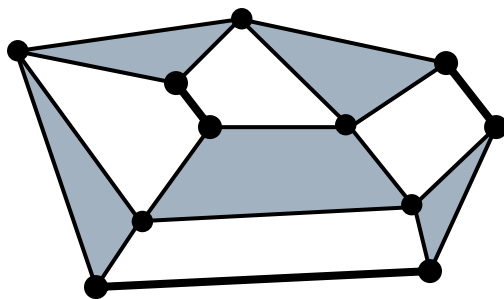

2

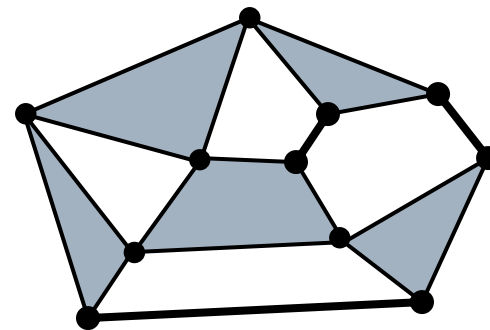

3

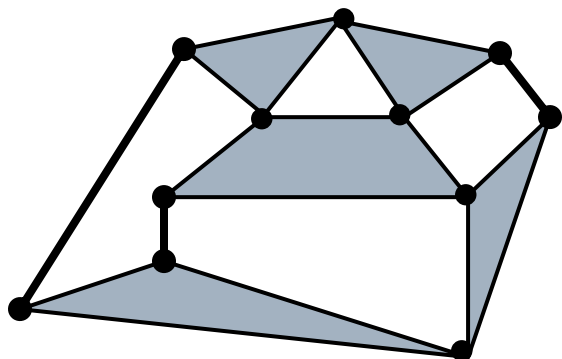

4

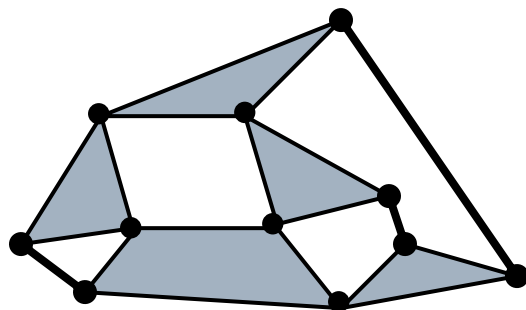

5

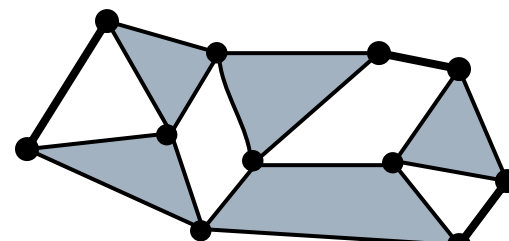

6

M	L	B	T	Q	P	Designation
-1	8	2	6	0	0	XXVIII

(Plus 11 more not shown)

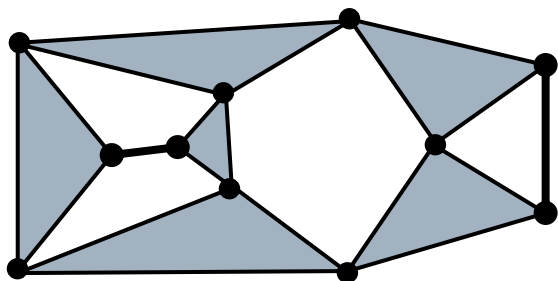

1

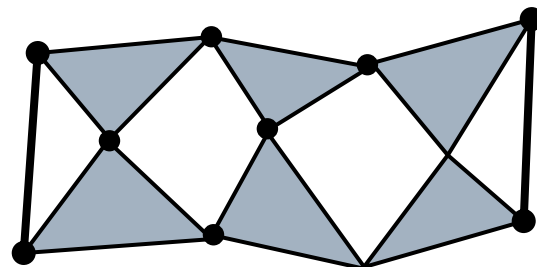

2

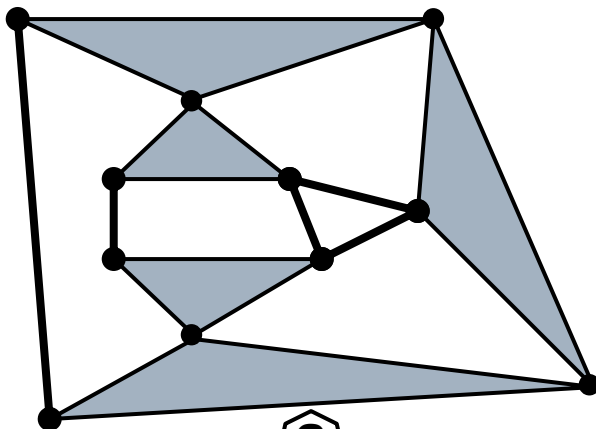

3

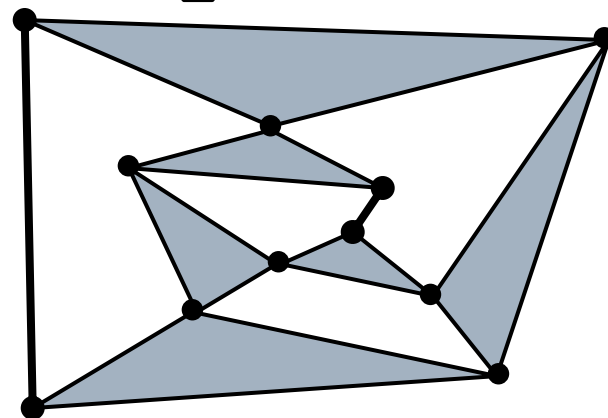

4

Link Combinations for Single Pin-Jointed Plane Linkages, $M=+2$

M	L	B	T	Q	P	Designation
2	5	5	0	0	0	XXIX
	7	6	0	1	0	XXX
	7	5	2	0	0	XXXI
	9	7	1	0	1	XXXII
	9	7	0	2	0	XXXIII
	9	6	2	1	0	XXXIV
	9	5	4	0	0	XXXV

M	L	B	T	Q	P	Designation
2	5	5	0	0	0	XXIX

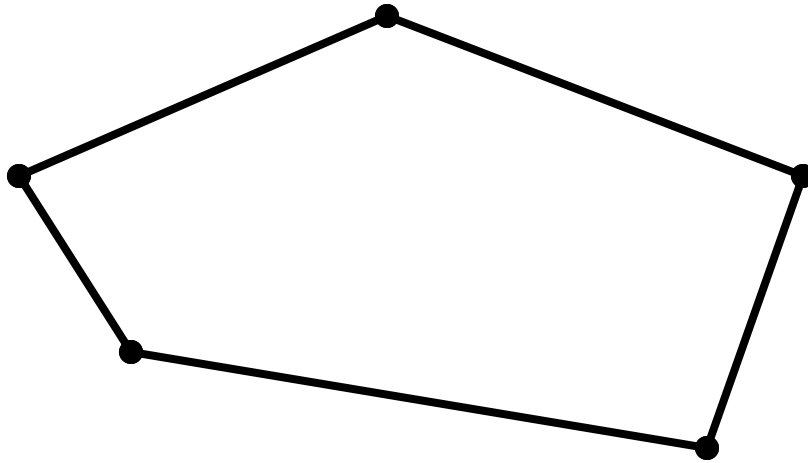

1

M	L	B	T	Q	P	Designation
2	7	6	0	1	0	XXX

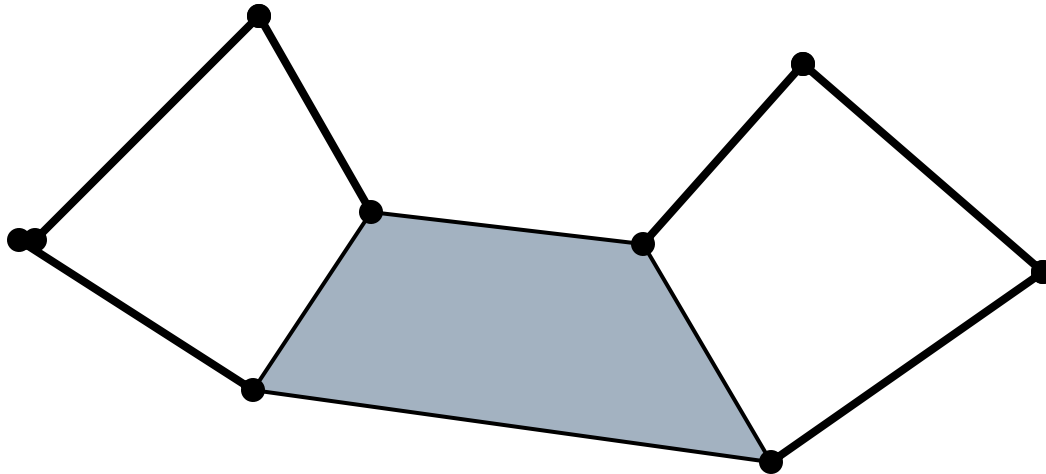

1

M	L	B	T	Q	P	Designation
2	7	5	2	0	0	XXXI

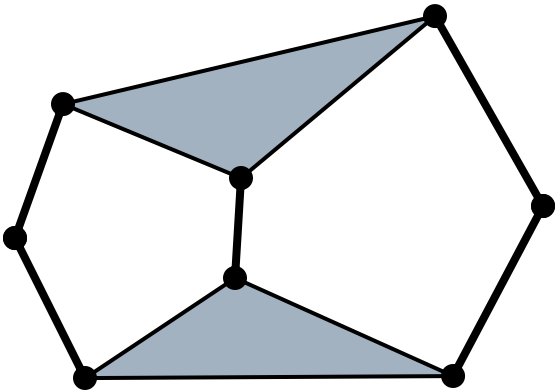

1

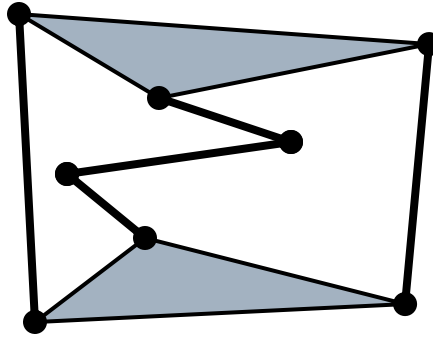

2

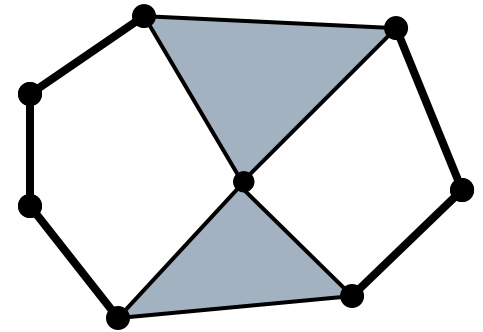

3

M	L	B	T	Q	P	Designation
2	9	7	1	0	1	XXXII

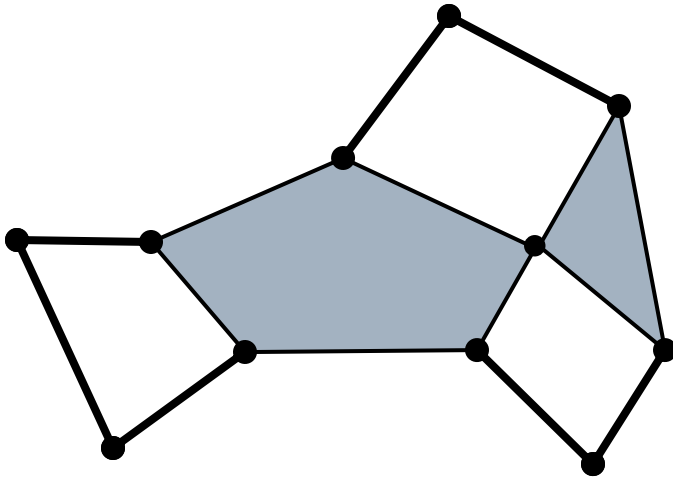

1

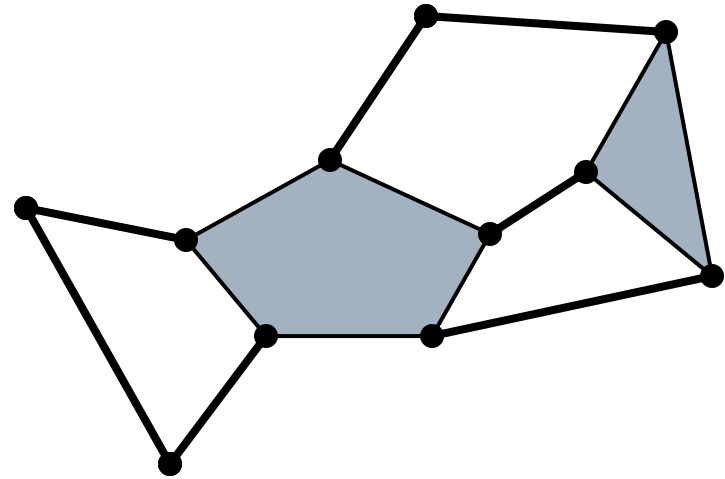

2

M	L	B	T	Q	P	Designation
2	9	7	0	2	0	XXXIII

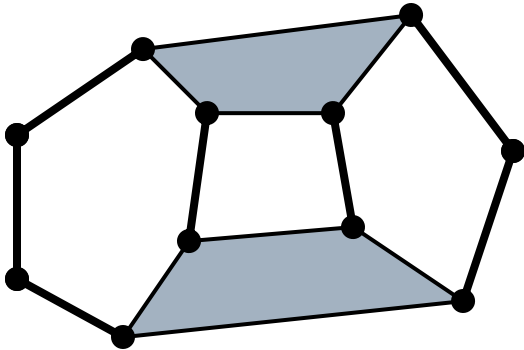

1

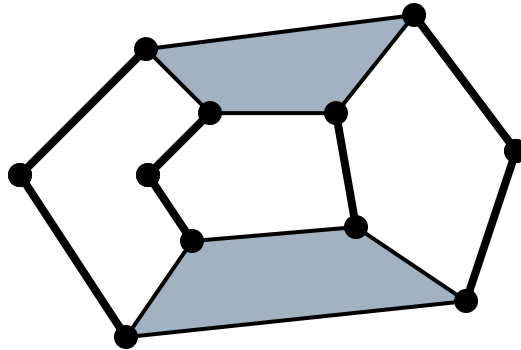

2

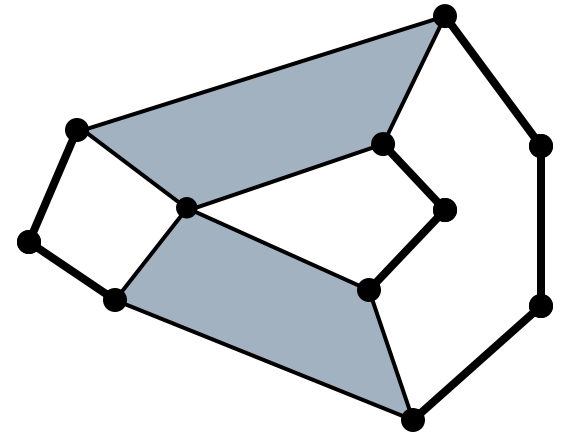

3

M	L	B	T	Q	P	Designation
2	9	6	2	1	0	XXXIV

(Plus 10 more not shown)

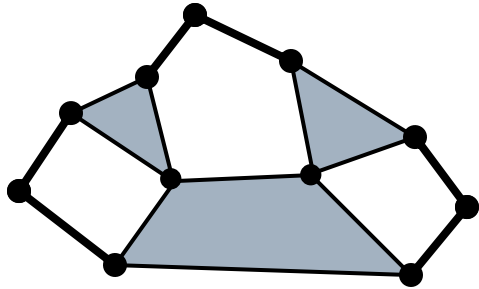

1

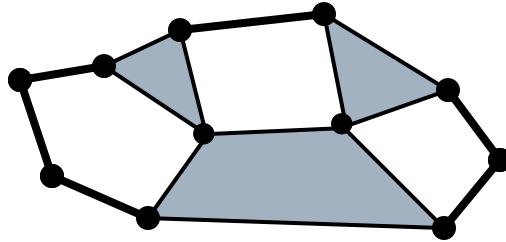

2

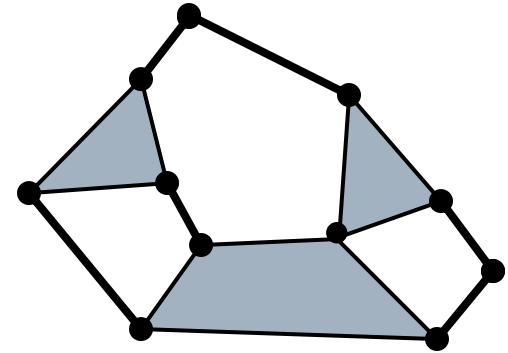

3

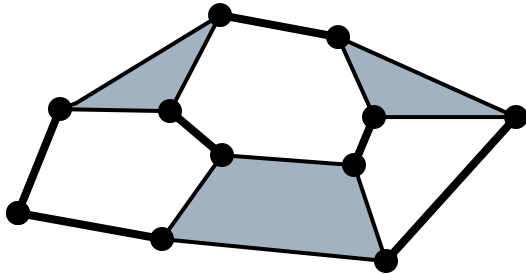

4

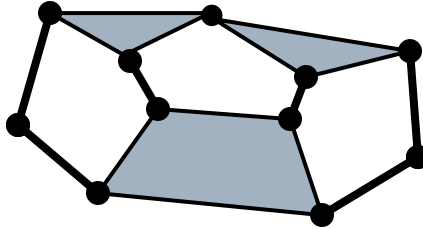

5

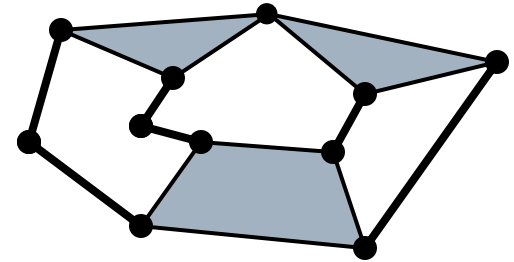

6

M	L	B	T	Q	P	Designation
2	9	5	4	0	0	XXXV

(Plus 11 more not shown)

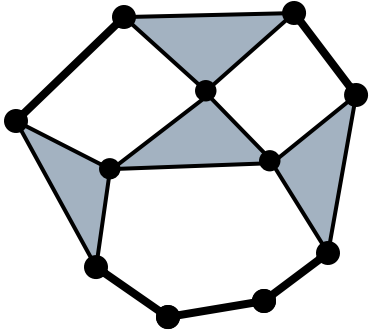

1

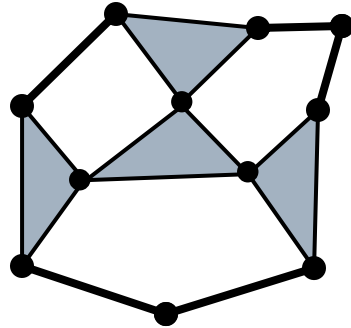

2

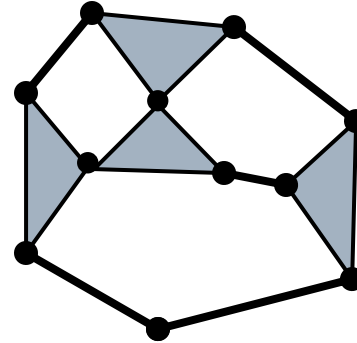

3

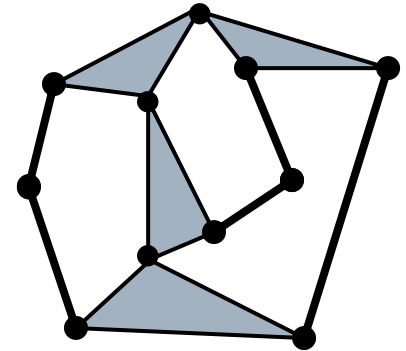

4

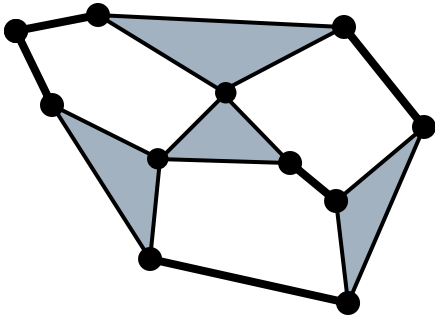

5

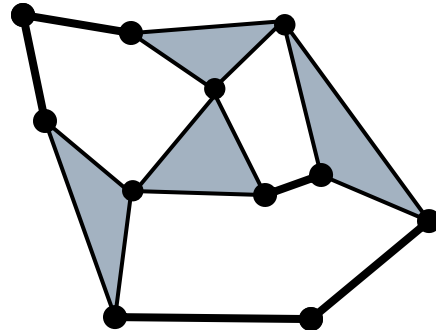

6

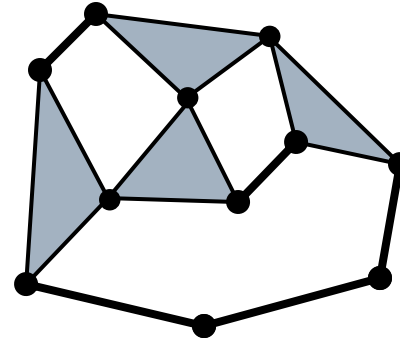

7